



COMAC CAL

**CZECH PRODUCER
AND DEVELOPER
OF MEASUREMENT
AND SENSOR TECHNOLOGY**

FLOW 38DNV

Ver.8.2x

Installation and technical conditions

Date of issue 28/10/2023

WWW.COMACCAL.COM

Contents:

Description of device	4
Scope of delivery	4
Storage conditions	5
Warranty	5
Installation in pipeline	6
Important information for selection of location	6
Sources of disturbances.....	6
Installation examples.....	7
Actual installation in pipeline	9
Installation check	16
Wiring	17
Important information	17
Installation of the meter's detached evaluation unit	18
Meter wiring.....	19
OUT1 / OUT2	20
Current output	21
The external button to reset the user volume Vnull	22
Data output.....	22
Protection degree.....	22
Replacement of tube fuse in the meter.....	23
Wiring check	23
Putting into operation	24
FLOW 38DNV OPERATING INSTRUCTIONS	25
Basic button functions.....	25
Special button functions.....	25
Password setting.....	25
Basic menu	26
Flow meter settings	27
Expansion module	38
Turning the FLOW 38DNV display	41
User adaptation	41
Technical data	43
Factory settings	45
Table with flow ranges for individual DN sizes	46
Basic sensor sizes	47
Nomogram for quick proposal of the measured place	51
Reduction in DN pipe	51
Faults and their symptoms during measurement	52

<i>Flow sensor cleaning</i>	52
<i>Servicing</i>	52
<i>Order code</i>	53
<i>Returning the meter to COMAC CAL s.r.o.</i>	54

Description of device

The FLOW 38DNV meter is based on measurement principle by a well-known Faraday's electromagnetic induction law according to which an electric voltage is induced during the flow of a conductive liquid through the flow meter magnetic field. This is picked up by two electrodes in direct contact with the measured medium and evaluated in the electronic unit.

The FLOW 38DNV type of induction meters are suitable exclusively for measurement of volumetric flow of electrically conductive liquid substances with a minimum conductivity of 20 $\mu\text{S}/\text{cm}$ (at a lower conductivity, upon agreement with the manufacturer).

Meters are designed for flow measurement where the velocity of liquid is in the range of 0.01...12 m/s. The best measurement accuracy can be obtained in the range of 1...10 m/s.

Scope of delivery

Accessories vary according to the variant of flow sensor and above standard optional features.

Threaded design

Electronic evaluation unit with a fixing bracket for wall mounting (not for the compact design), flow sensor (in case of compact design, the electronic unit is integral part of the flow sensor), connecting grounding cable, installation manual.

Sandwich design

Electronic evaluation unit with fixing adapter for wall mounting (not for the compact design), flow sensor (in case of compact design, the electronic unit is integral part of flow sensor).

Flanged design

Electronic evaluation unit with fixing adapter for wall mounting (not for the compact design), flow sensor (in case of compact design, the electronic unit is integral part of flow sensor), connecting grounding cable, installation manual.

Food industry design

Electronic evaluation unit with a fixing bracket for wall mounting (not for the compact design), flow sensor (in case of compact design, the electronic unit is integral part of the flow sensor), adapter piping connection according to DIN 11851, installation manual.

In case of detached design, a special cable for connection of the meter (it must not be extended or cut short) is part of the flow sensor.

Storage conditions

The temperature during transportation and storage of the meter must be within the range of -10 °C to 50 °C.

Wooden boards installed on the flanges in the factory are used for protection of lining on the flanges during storage and transportation (for PTFE lining). Remove these protective boards just before installing in the pipeline!!!

Do not lift the flanged meters by the transducer head or by the connecting box of the detached design during transportation! Use slings and place them round both process connections for transportation of meters up to DN150 (chains may damage the meter head)! Use only the holes between the flanges and sensor for transportation, lifting and installation of the sensor in piping in case of DN200 and bigger!!!

Warranty

Unprofessional installation or using the induction meters (devices) may result in a loss of warranty as well as failure to comply with installation or operating conditions according to this manual.

Installation in pipeline

Important information for selection of location

!!! In case of detached design, the cable must not be extended or cut short !!!

Outdoor conditions

It is necessary to ensure that the flow sensor is not exposed to weather effects and that the measured medium cannot freeze in the flow sensor as it would damage the measuring tube.

In case of outdoor location of the electronic evaluation unit, the manufacturer recommends using a protective box or a roof to avoid direct solar exposure so that the evaluation electronics cannot get overheated.

Sources of disturbances

The following items rank among the most frequent sources of disturbances to the steady flow of liquid:

- Abrupt changes in pipe cross-section if not performed as a cone with an angle of $\alpha \leq 7^\circ$ (where α is the angle made by bevelled walls of the pipe reduction).
- Incorrectly centred sealing, low ID sealing or sealing made of soft elastic materials which are pushed out into the interior pipe cross-section after flanges are tightened.
- Anything interfering in the flow of liquid, for example thermowells, branch pipes, T-pieces, bends, elbows, slide valves, cocks, flap valves, shut-off valves, control valves, butterfly valves and check valves. Pipe outlets from tanks, heat exchangers and filters.
- No intensive magnetic fields in the proximity of the induction flow sensor (detector) must be present.

No sources of disturbances affecting the steady flow must be present in the straight pipeline sections. They must be located in the piping after the flow sensor or at the farthest distance before it. Sources of disturbances may substantially reduce the measuring range and accuracy of the flow meters.

Vibration

We recommend supporting the connecting pipes on both sides of the meter for partial elimination of vibrations. Levels and range of vibrations must be under 2.2 in the frequency range of 20...50 Hz according to IEC 068-2-34. If the pipeline is exposed to excessive vibrations (e.g. from pumps), using compact meters is not recommended.

Actual location

The flow sensor (detector) must not be at the top position of the pipe which may be airlocked, or in declining or even in horizontal pipelines with open ends in which air may penetrate. Impurities may accumulate during long-term measurement of very low flow rates $Q < 0.1$ m/sec. There must be a sufficient pressure in the place of flow sensor installation so that the expulsion of gas or vapour bubbles from the liquid is avoided. Little bubbles that always occur in liquids may accumulate at any of the electrodes and this may result in incorrect operation of the meter. Gas bubbles are expelled also at an abrupt pressure drop. Therefore, butterfly valves and similar elements should be located **after the flow sensor**. For the same reason, the flow sensor should not be placed at the suction side of the pump. To prevent the bubbles from accumulation at a low flow in the flow sensor, it is suitable, e.g. that the pipe is slightly ascending or that the flow sensor is located in the vertical section of the pipeline.

If the meter is populated with measuring electrodes only (2 or 3 electrodes located **beyond the upper profile** of the tube), it is necessary for proper function of the meter, to fill up the flow sensor with the fluid to be measured so that erroneous readout of quantity of liquid passing through the meter can be avoided when the pipe is empty. It is necessary to select the location of the meter in such a way that the flow sensor aeration can be avoided. In the case of an open system, the flow sensor is placed in the bottom position of the U-profile pipework, ensuring that the fluid will not flow out of the sensor.

In the case that the sensor is equipped with an empty pipe testing electrode (3rd or 4th electrode in the upper part of the measuring tube profile), there is no risk of erroneous readout of quantity of liquid passing through the meter due to aeration of measuring electrodes. This function must be activated in PARAMETERS (EMPTY TUBE TEST) menu. If it be to the contrary, the same conditions apply as if the testing electrode is not populated.

The function of empty tube detection in horizontal mounting position operates correctly only if the evaluation unit is oriented upwards (see Fig. below). Alternatively, it is not possible to ensure that the activation of empty tube detection in case of partly filled or empty pipes will take place.

Due to the principle, it is necessary that the maximum conductivity of medium is 6000 μS for ensuring the functional evaluation of empty tube. Beyond this limit, errors may occur in empty tube test, and in this case, it is necessary to deactivate the empty tube test. If the conductivity of medium is beyond the permissible range, the meter may, despite the flooded system, register empty pipeline and the measurement will not start.

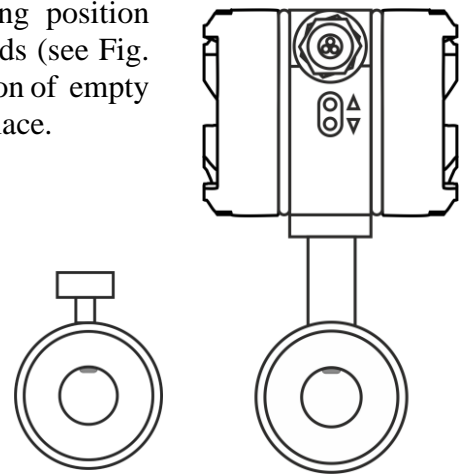

In case of any intervention into the measuring circuit must be accessed like a pipe is fulfilled of medium, and regardless of the displayed information “empty pipe test” on the display meter !!!

Installation examples

Trouble-free and exact operation of the meter is dependent on its correct location in the system. The most frequent methods of the placement are shown in the following figures:

Recommended installation locations

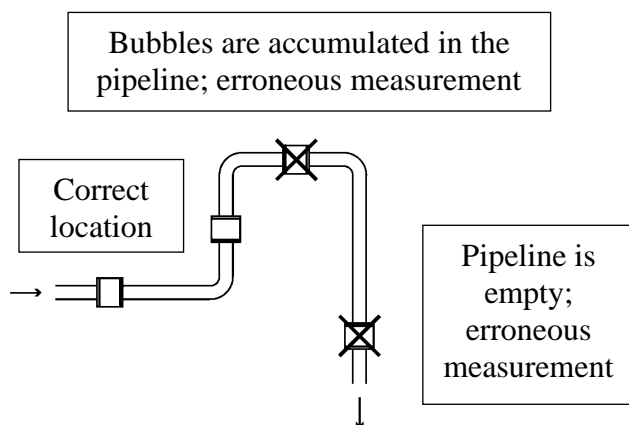

Downtake pipe

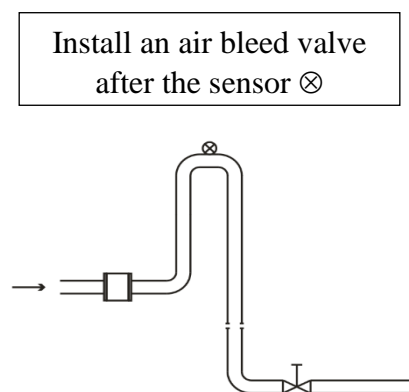

Horizontally laid pipeline

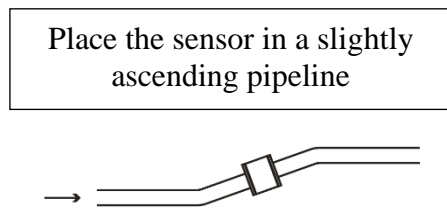

Long pipeline

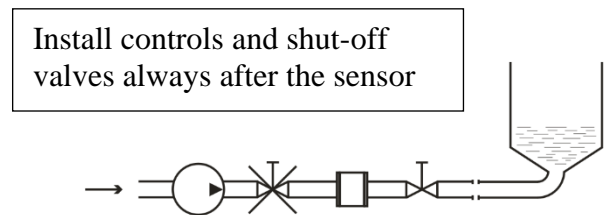

Free inlet or outlet

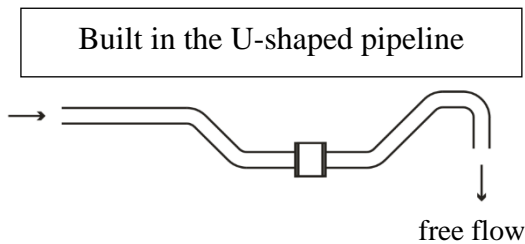

Pumps

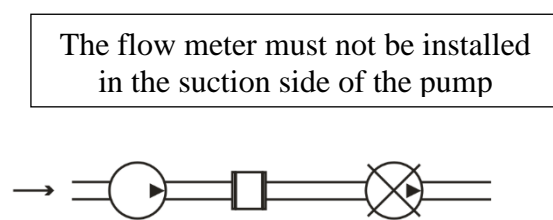

The flow of liquid flow in the flow sensor should be **steady and free of whirling**. For this reason, straight sections of pipeline with the same ID as that of the flow meter before and after the flow sensor (with permissible deviation of +5%). Recommended minimum length of straight sections is $5 \times d$ before the flow sensor and $3 \times d$ after the flow sensor where d is the inside diameter of the meter in millimetres. The same principles apply before and after the flow sensor in case of bi-directional flow measurement.

Recommendations

- In case of whirled up flow, extend the calming sections of pipeline or integrate a flow conditioner.
- When blending a mixture of substances, it is necessary to install the flow meter either before the point of blending or at a sufficient distance after it ($30 \times d$ min. where d is the inside diameter of the meter in millimetres), otherwise it will result in instability of indication.
- When plastic pipeline is used or in case of metallic pipes with internal non-conductive layer, earthing rings are needed.
- Do not install the sensor at the suction side of the pumps; this will eliminate the risk of vacuum and possible damage to the measuring tube lining.
- Pumps, bends and elbows found closely in succession in various levels should be at a distance of $20 \times d$ at least before the flow sensor. In case of a separate elbow or bend, the placement $10 \times d$ before the meter is recommended.
- When piston pumps, diaphragm pumps, and flexible tube pumps are used, it is necessary to install a pulse damper in the system.
- In order to provide the highest accuracy, it is important to ensure permanent flooding for the sensor (for example, by installation of the sensor in the U-shaped pipeline) even if the sensor is equipped with empty tube test. This will serve as an additional safety measure for detection of non-flooded tube.

The responsibility for suitability and adequacy of application of induction flow meters is borne by the designer or possibly the user himself.

Actual installation in pipeline

When welding both counter-flanges to the pipelines, it is necessary to maintain their **alignment** so that levelness of bearing surfaces of the flanges onto the front faces of the detector is ensured (at the same time, this must not be achieved by unequal tightening of the bolts as there is a risk of leakage due to thermal loading in the future or the measuring tube may break during such tightening). The difference of L_{MAX} and L_{MIN} distances of the sealing surfaces of the flanges before the flow sensor is installed **must not be greater than 0.5 mm**.

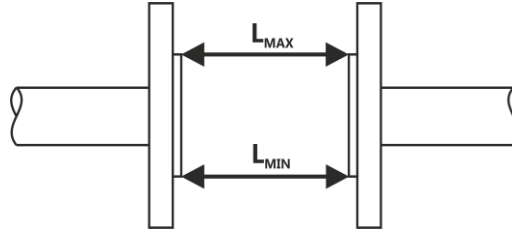

The opposition of the holes in the counter-flanges for the bolts should be ensured in the same manner and a sufficient room behind the flanges should be available for the bolts and nuts so that the actual installation of the sensor in pipeline and its attachment with the bolts is made possible.

The manufacturer recommends using an intermediate piece during welding. It is absolutely excluded to use the flow sensor as an intermediate piece due to thermal damage. The welding current must not run through the flow sensor during electrical welding. The installation of the flow sensor is carried out after welding, coating, building and similar works are completed.

The actual installation is performed by the fixation between the counter-flanges that are welded to the calming pipeline ($5 \times d$ before and $3 \times d$ after in the direction of flow) whereas the liquid must run through the flow sensor in the direction **indicated by the arrow** on the sensor name plate.

During installation, do not lift the meter by the evaluation unit housing (in case of detached design, by the sensor terminal box), possibly under the meter's metallic housing but always use slings round the process connection or use the lifting lugs on the flanges.

Installation position

The inductive flow sensor is installed in arbitrary position in vertical piping. In case of horizontal piping, it is necessary to make sure that the sensor is installed with its measuring electrodes in horizontal position. In case of the earthing electrode design, possibly with testing for empty pipeline, then the installation is always performed with the earthing reference electrode facing down (with the sensor terminal box, eventually with the evaluation unit facing upwards). Then the earthing reference electrode is in the bottom position and the empty tube sensing electrode is in the top position of the flow sensor.

Every time when the empty tube testing electrode is not covered with a liquid for 5sec at least, the flow meter will display the "Empty tube" status, and if it is necessary, it sends out an error message and stops taking measurement.

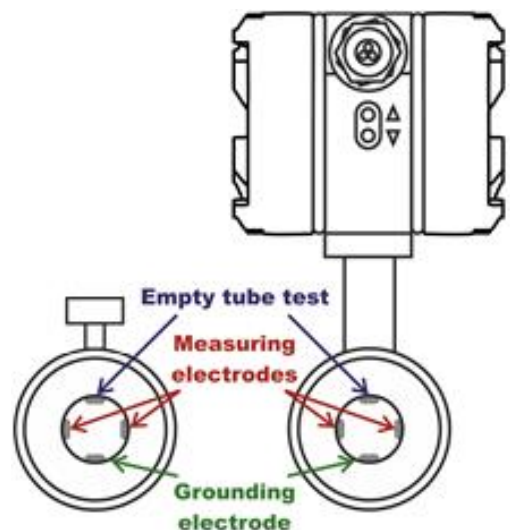

The measurement accuracy is maintained in this way. Once the electrode is covered with the liquid again, the error message disappears and the flow meter starts taking measurement again.

Measurement error caused by incorrect mounting installation

1) *correct installation (flow sensor should be install in arbitrary position in vertical piping)*

EMPTY TEST – ON

EMPTY TEST – OFF

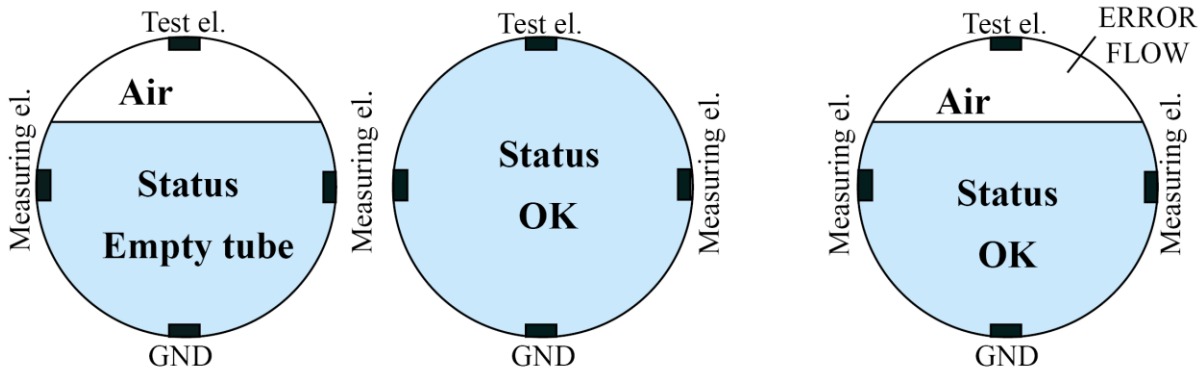

2) *incorrect installation (placing the unit diagonally, Empty test – ON)*

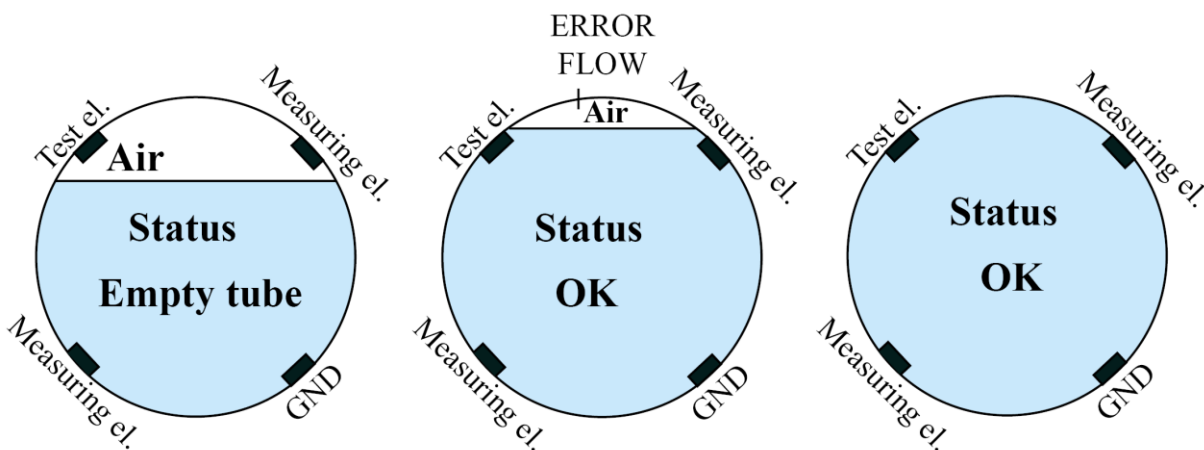

Installation in piping and placement of measuring electrodes in flow sensor

1) in the version without the earthed reference electrode and/or empty piping test (2 electrodes)

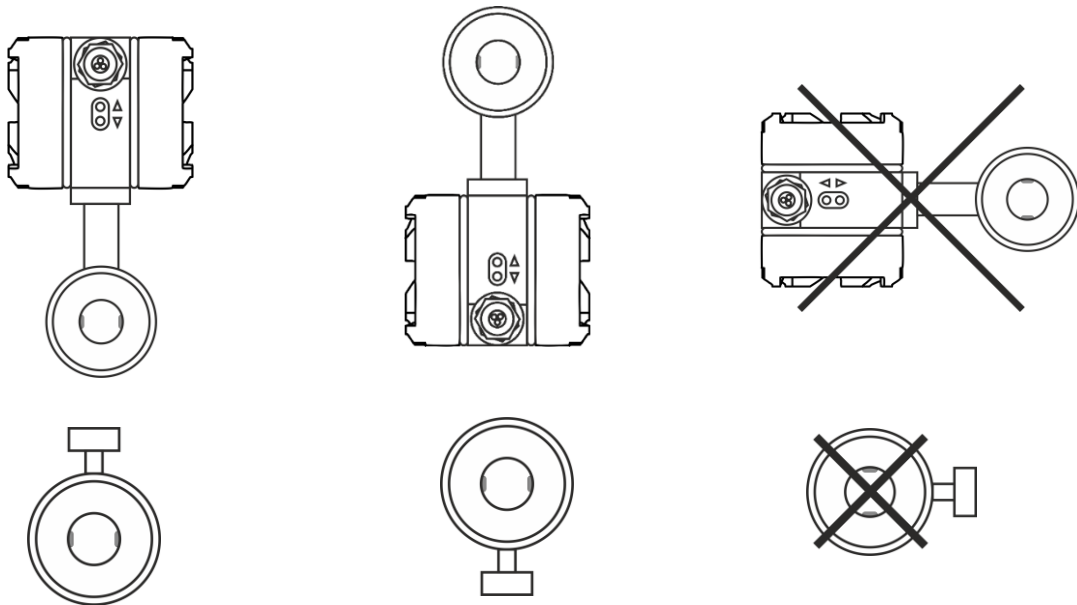

2) in the version with earthed electrode and/or empty piping test electrode (3/4 of the electrode)

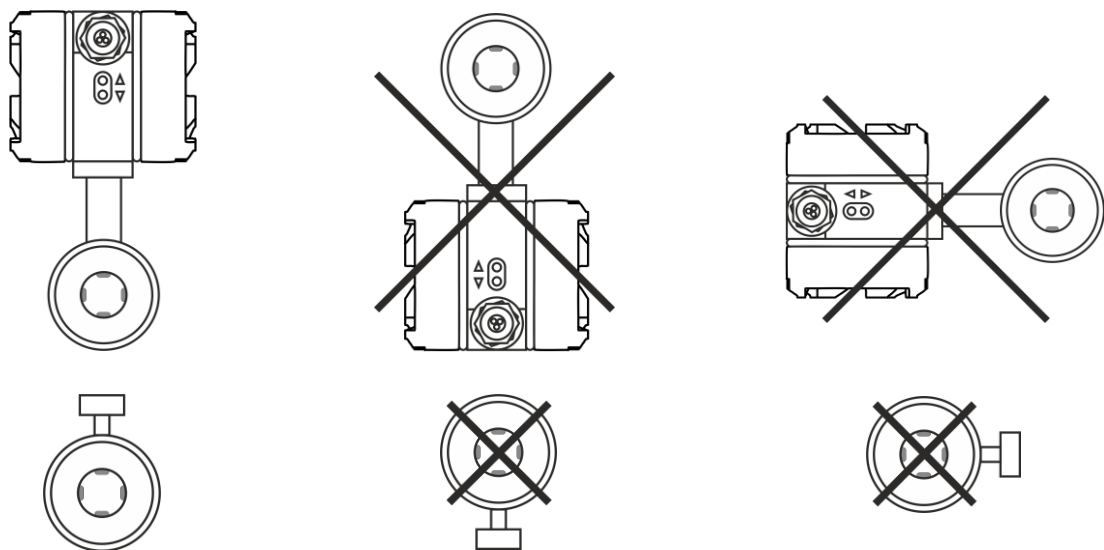

During installation, beware of:

- dropping the meter onto the ground and damaging the measuring tube or electronics
- contamination of the electrodes (do not touch the electrodes, otherwise they get contaminated)
- when additional sealing is used, avoid its interference in the flow profile of the detector between the flanges and the pipeline, otherwise the flow measurement error may be increased

Tightening torques

It is absolutely necessary to tighten the bolts and nuts equally by alternating sides and in the order shown in figure applying the maximum torque according to the table.

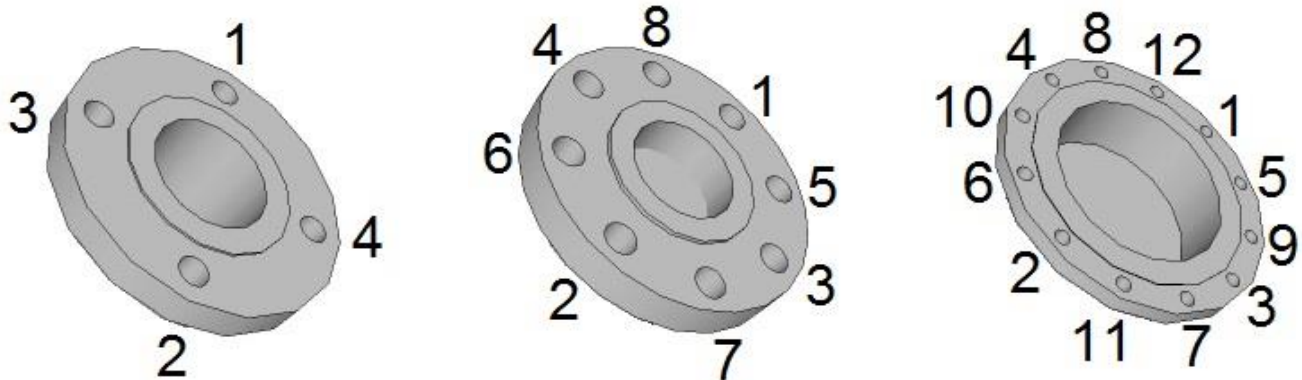

If the bolts are tightened too much during the installation of pipework components, deformation of the sealing surface may occur. In consequence, the torque values indicated in the table are used as a guidance for tightening the screws and bolts.

Table with tightening torques for screws/bolts (EN 1092-1):

Diameter nominal DN	PN 10			PN 16		
	Screws	Tightening torque [Nm]		Screws	Screws	
		Rubber	PTFE,PFA ETFE, PVDF		Rubber	PTFE,PFA ETFE, PVDF
10	4 x M12	10	15	4 x M12	10	15
15		15	20		15	20
20		20	25		20	25
25		20	25		20	25
32		20	25		20	35
40	4 x M16	20	25	4 x M16	20	35
50		20	45		20	45
65		20	46		20	46
80		20	48		20	48
100	8 x M16	20	50	8 x M16	20	50
125		20	80		20	65
150	8 x M20	24	90	8 x M20	27	90
200		27	115		12 x M20	35
250	12 x M20	35	95	12 x M24	55	100
300		50	100		80	110
350		16 x M20	60		70	16 x M24
400	16 x M24	75	120	16 x M27	140	150
500	20 x M24	100	150	20 x M30	250	230
600	20 x M27	165	240	20 x M30	400	360

Diameter nominal DN	PN 25			PN 40		
	Screws	Tightening torque [Nm]		Screw	Tightening torque [Nm]	
		Rubber	PTFE, PFA, ETFE, PVDF		Rubber	PTFE, PFA, ETFE, PVDF
10	4 x M12	15	15	4 x M12	15	15
15		20	20		25	25
20		25	25		25	25
25		25	25		25	25
32		25	35		25	40
40	4 x M16	25	35	4 x M16	35	50
50		35	45		35	60
65		35	46		45	55
80	8 x M16	40	48	8 x M16	45	60
100		40	55		50	75
125	8 x M24	50	110	8 x M24	70	120
150		57	115		75	136
200	12 x M24	68	100	12 x M27	85	145
250	12 x M27	88	120	12 x M30	105	220
300	16 x M27	95	125	16 x M30	115	250
350	16 x M30	115	200	16 x M33	140	-
400	16 x M33	135	255	16 x M36	165	-
500	20 x M33	350	430	20 x M36	-	-
600	20 x M36	600	740	20 x M45	-	-

In case of using a corundum or thermoplastic tube, the same torques apply as in case of using the PTFE tube according to the given pressure series.

Threaded connection (EN 10226-1):

Diameter nominal DN	Process connection [inch]	Tightening torque [Nm]
10	3/8"	8
15	1/2"	10
20	3/4"	21
25	1"	31
32	1 1/4"	60
40	1 1/2"	80
50	2"	5
65	2 1/2"	6
80	3"	15
100	4"	14

If you do not find your size or structure in the Torque Table, it is a special or non-standard design. In such a case, contact the manufacturer for more detailed information.

It is necessary to do the tightening three times, whereas for the first time, to 50% of the maximum torque according to the above given Table. For the second time, to 80% and for the third time, to 100% of the maximum torque. We recommend checking the screws/bolts for tightening some 24 hours after installation of the meter.

When installing the flow sensors over 200 mm, it is necessary to follow, except for the above mentioned rules, also simultaneous tightening of parallel screws on both opposite flanges to avoid possible damaging the electrodes or the measuring tube (symmetrical tensioning of the lining).

If the flanged joint is not tight, although all of the screws are tightened closely, **these must not be tightened more** but slackened on the opposite side to the untightness and tightened on the other side. If the untightness manifests itself even after that, it is necessary to check the sealing surfaces for scratches or mechanical impurities. If the scratches or any other damage are deeper than some 15% of the thickness of the flange, it is possible to remove them using fine emery paper.

In case of the threaded connection, it is necessary to check, while tightening, the screwed connection on the sensor so that torsional displacement is avoided.

Seal

The turned up part of the lining does not carry out the function of sealing so it is necessary to insert the appropriate seal precisely centred between the sensor and the pipeline. If the sealing extends in some place into the flow profile, it makes whirls and reduces the measurement quality. Use the seals compatible with the liquid and 5mm thick. Do not use graphite or any other electrically conductive material to hold the sealing in place during installation. It could influence the measuring signal accuracy.

Earthing

For reliable and correct operation of the induction sensor it is necessary to provide proper protective and working earthing. The earth line must not transmit interference voltages so the other electrical devices must not be earthed by means of this line.

The flow sensor is provided with the M5 earthing screw of stainless steel with a washer and nut for proper connection of the sensor body with both counter-flanges of the metallic pipeline. The earthing cable lug is screwed there and it should be conductively connected with the counter-flanges. On the counter-flanges, it is recommended their connection to the welded crews or into a threaded hole. Connecting under the fixing screws of the flange is not suitable as they may corrode with time and cause failures in measurement.

However, if it is not ensured that the counter-flanges are in direct contact with the measured media and they are conductive, the earthing rings must be used, refer hereinafter.

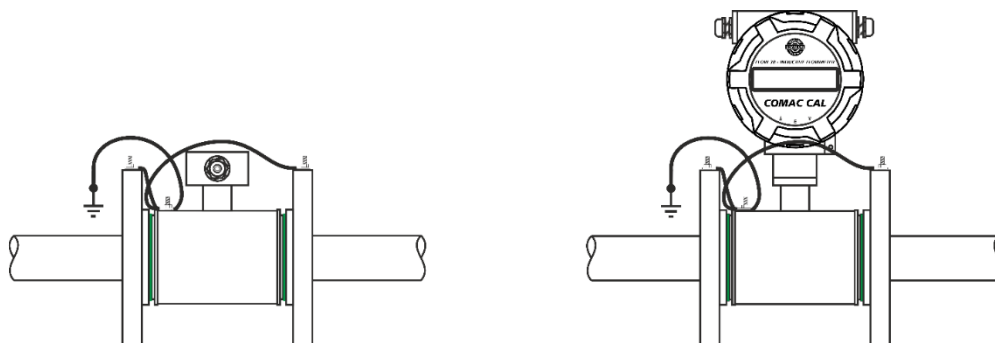

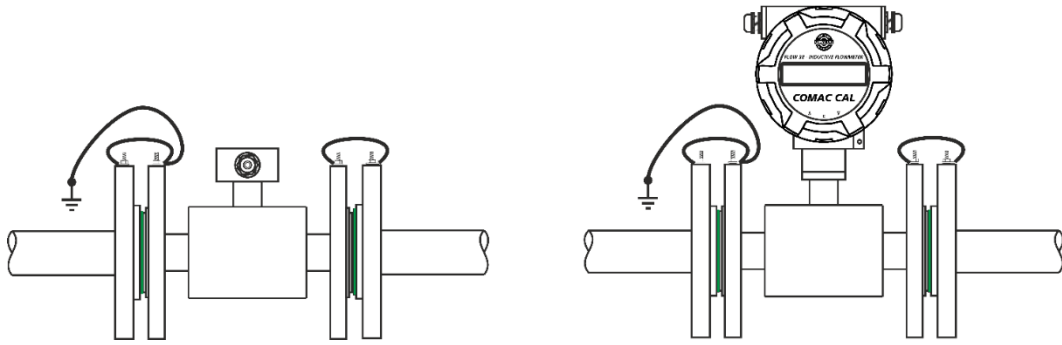

Earthing rings

Using for a plastic pipeline or in case of metallic pipelines with internal plastic lining turned up or pulled out to the front faces of the pipeline flanges. Conductive earthing rings of stainless steel create conductive connection with the measured substance. Usually, potential equalization is carried out by means of the reference earthing electrode in the measuring tube. In exceptional cases, the equalizing currents may run through the reference electrode based on the device earthing conception. This may lead to deterioration of the sensor, e.g. by electrochemical disintegration of the electrodes. In such cases, it is **necessary** to use the earthing rings for potential equalization. This holds true for two-phase or two-component flows in which the medium is blended badly or its components cannot be blended. In general it can be said that using the earthing rings is always the protection against stray currents and the warranty of correct measurement at the same time.

The flow sensor is provided with the earthing screw of stainless steel for the earthing cable supplied with the mounting accessories. Then this cable must be conductively connected with the earthing rings.

The earthing rings are not part of our standard package and must be ordered separately. Chemical durability of the material must correspond with the liquid to be measured; it is usually made of the same material as the sensor electrodes. While mounting, it is necessary to insert seals in both sides of the earthing ring and take care that no part extends to the internal profile of the sensor (whirling and turbulence of the medium).

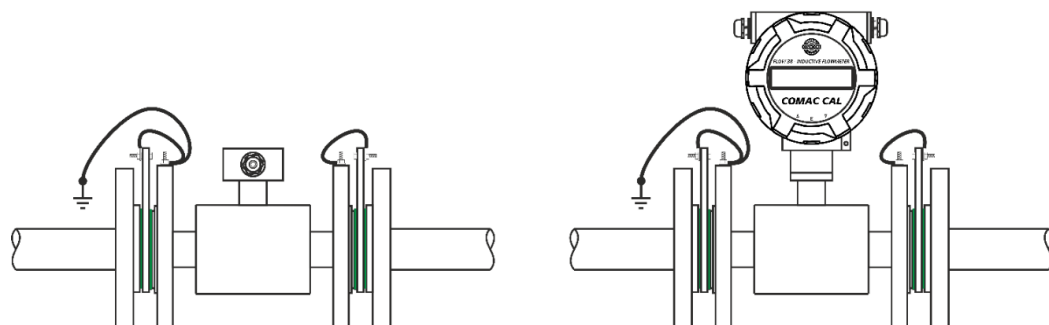
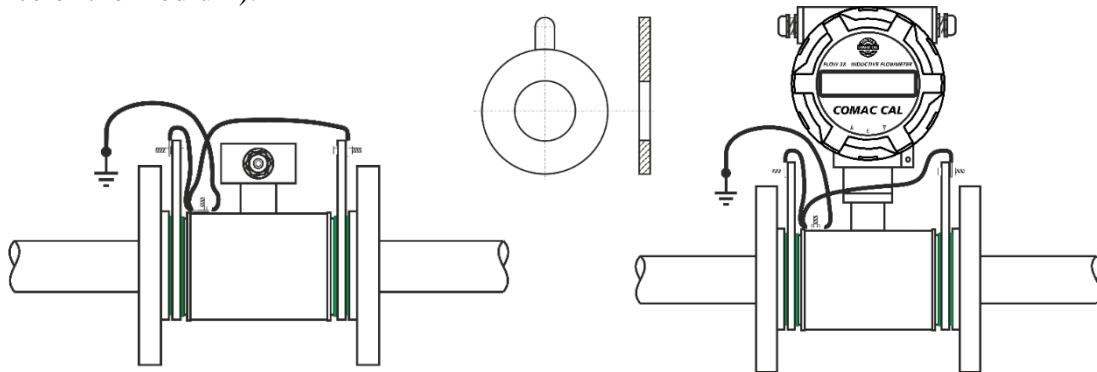

Electrodes

The electrode material must be selected according to chemical resistance to the liquid to be measured. The purity of the electrodes may have an influence on measurement accuracy, their heavy foulness may cause even the interruption of the measuring function (isolation from the liquid). It is not necessary to clean the electrodes right after delivery before their installation in the pipeline. If the electrodes indicate signs of foulness, clean them with a soft cloth or use a chemical cleaning agent. Mind damaging to the lining! During routine operation, in case of a great majority of liquids, it is not necessary to clean the flow meter for the entire operation period of the flow sensor; self-cleaning by flow of the liquid is sufficient (recommended velocity is over 2 m/sec).

PTFE, PFA, EFTE lining

Meters with PTFE lining are equipped with protective covers to prevent the sealing surfaces from damaging during transportation or storage and from changing the shape (due to elastic memory of the PTFE material, it is restraightened to the tube). Protective covers may be removed only right before the installation. If these covers are removed due to a check, it is necessary to replace them immediately. Carry out the installation at the lowest point of the pipeline to avoid the occurrence of vacuum. Never detach and damage the rim of the PTFE lining turned up to the of flow sensor faces. Remove the covers from the inlet and outlet sides right before insertion of the sensor between the pipeline flanges and replace them with metal plates (0.3...0.6 mm thick). After insertion of the sensor, remove the metal plates and install the screws/bolts.

High temperature pipeline

High temperature medium

At temperatures of the medium to be measured over 100°C, it is necessary to compensate the forces caused by thermal expansion of the pipeline due to its temperature rise. For short pipelines, it is necessary to use flexible seals, for long pipelines, use flexible pipe elements (e.g. bends).

The flow sensor must never be thermally insulated. In case that the sensor is placed in a thermally insulated pipeline, the thermal insulation must be interrupted and the flow sensor is installed without thermal insulation.

When a compact meter is used (evaluation unit placed on the sensor body), it is necessary to respect the temperature of medium up to 90 °C. In case of exceeding this temperature, the correct functionality of the electronic evaluation unit is not guaranteed, or there is a risk of its destruction.

Installation check

After installation of the flow sensor in the pipeline, the following must be checked:

- According to the name plate, if there is a relevant meter in the given measuring point (pressure, temperature, dimension, etc.).
- If the direction of the arrow on the device is in agreement with the direction of the flow in the pipeline.
- Correct position of the measuring electrodes (horizontally).
- Correct position of the electrode for empty pipeline detection (up).
- If all bolts (screws) are tightened properly.
- If earthing rings are used, then their correct installation and connection with the sensor.
- Accuracy of flow sensor earthing.
- Accuracy of execution of the pipeline calming section lengths
- If the sensor is protected against vibrations and mechanical damage.
- If the name plate (serial number) on the sensor corresponds to the one on the electronics.

Wiring

*Workers performing wiring are subject to the requirements of Decree No. 50/1978 Coll. on activities on electrical equipment!!! When the operations described below are performed unprofessionally, the claim on warranty becomes extinct!!! Prior to any opening of the evaluation unit, switch off the power!!! It is necessary to bear in mind that in case of detached design, the electronic evaluation unit and the flow sensor form an integral unit which is calibrated and matched uniquely. In consequence, make sure that **the serial numbers of both parts are always identical!!!***

Important information

Flow sensor connecting cable

The signal cable of the detached induction flow sensor cannot be led in parallel (even partly) with the cables for power distribution voltage or in the proximity to electric motors, electromagnets, contactors, frequency converters and similar sources of electromagnetic interference. In unavoidable situations, it is necessary to put the cable in an earthed iron tube. Primarily in media with a low conductivity, cable movements and interference may result in distortion of the measured signal. The maximum length of the cable between the sensor and the evaluation unit is 30 metres provided that the conductivity is over 50 μ S/cm. In case of lower conductivities, it is recommended to use the shortest possible cable length, however, 10m max.

In case of detached designs, it is possible to interconnect only the sensor and the transducer with the same serial numbers. The special cable for connection of the detached meter design must not be extended or cut short. In case of infringement of these requirements, measurement failures and significant inaccuracies may occur once the meters are connected.

If it is possible to expect an increased level of unwanted electromagnetic field, we do not recommend using the detached design. In places with strong electromagnetic interference (in the proximity of frequency converters, electric motors, transformers, etc.), we recommend putting a line filter before the meter in the power supply circuit.

Evaluation unit

As standard, the evaluation unit is delivered for mains power supply 230V / 50...60Hz. It is possible to specify also DC power (as standard, 24V AC/DC / 250mA).

For securing the tightness of the evaluation unit cover, it is necessary to keep the seal intact and clean (replace the damaged seal immediately). If the holes for cable entries are not occupied, it is necessary to do it.

The flow meter signal outputs may only be connected to devices where accident protection is provided by a safe low voltage and where generated voltages do not exceed the limits defined for safe low voltage.

In case of mains power 230V / 50...60Hz, the meter is fed by a switched power supply which may contain beats in acoustic spectre whereas this symptom does not indicate a failure of the meter.

Never make kinks on the cable and on individual conductors and do not let them cross mutually in the terminal board area and always use a separate cable grommet for power supply. Cover the unoccupied grommets with a piece of cable or a plastic plug (securing of tightness).

Installation of the meter's detached evaluation unit

The design HEAD (H) – it is a standard design with a possibility of installation both in compact and detached designs (as per purchase order)

Firstly decide if you want to install the fixing bracket behind, or under the electronics (the bracket with holes upward or downward). Install the fixing bracket on the meter's aluminium housing; place the unit as required on the wall or on a structure and mark the holes in this position for the attachment of the bracket. Unscrew the bracket and attach it to the marked location, e.g. using wall plugs and screws. Screw down the electronics on to the fixing bracket and connect the sensor cable using the connector. Attach the cable to the wall or to the structure so that it does not "dangle" from the connector. Make a "drip loop" downwards so that water cannot trickle onto the connector. Fix the conductors for power and the outputs in a similar way. After installation of all cables, turn the electronics to the required position and fix the unit to the bracket by tightening the fastening nut.

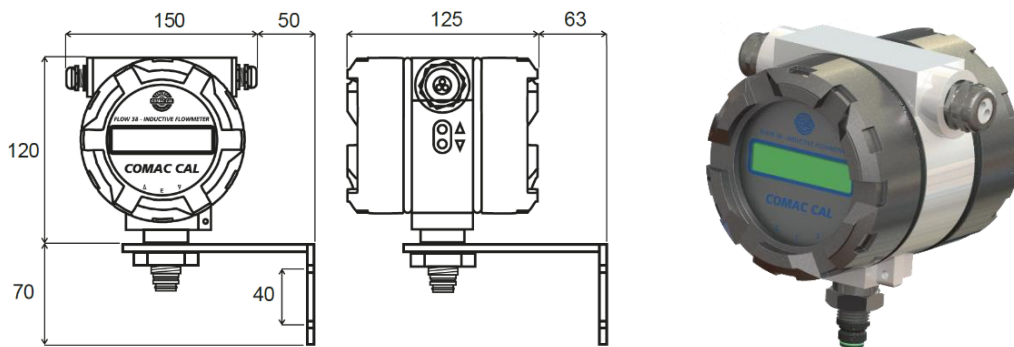

The FRONT (F) design – this design can be positioned again as the compact or detached ones
Wall mounting:

At first, unscrew the DIN rail holder from the unit by slackening two screws from the bottom of the box. After that, attach the unit without the top cover to the wall into the desired position and mark the internal holes (in corners of the 63x145mm rectangle). Drill the holes and put in the wall plugs, use the screws to fix the unit to the wall and connect the flow sensor cable using the connector. Attach the cable to the wall or to the structure so that it does not "dangle" from the connector. Make a "drip loop" downwards so that water cannot trickle onto the connector. Fix the power conductors (possibly outputs) in a similar way and complete the installation by closing the unit with the cover and tightening it.

Din rail installation:

Installation is carried out by locking the holder located on the bottom part of the unit into the DIN rail. After that, connect the connector of the flow sensor cable with the power cable (possibly outputs) and close the unit with the cover and tighten it in a similar way as in the case of wall mounting.

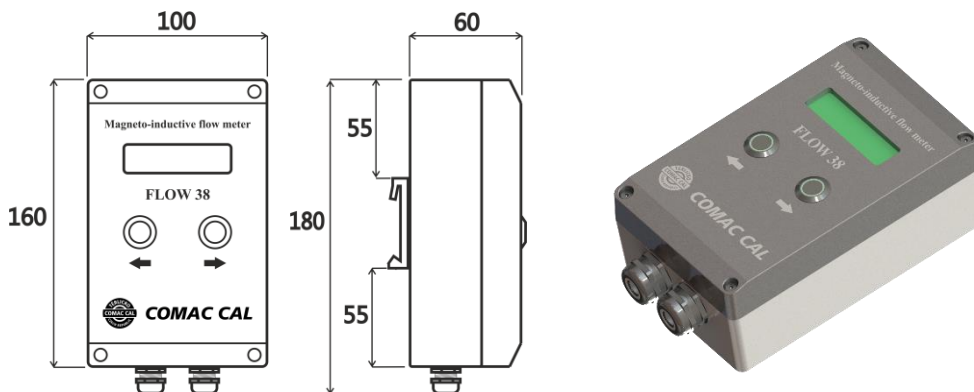

The PANEL (P) – this design is modified for building in panel areas, ideally into door, etc. where Built-in installation is desirable.

The installation of the evaluation unit is carried out by cutting a 110x110mm square opening with an overall area considered for the 140x140mm unit. Remove the square frame from the unit whereas the sealing is left on the unit. After pulling the unit through the installation opening, put on the frame from the rear side and tighten it with four inserted screws in the lateral holes so that the unit is stabilized and prevented from a possible displacement.

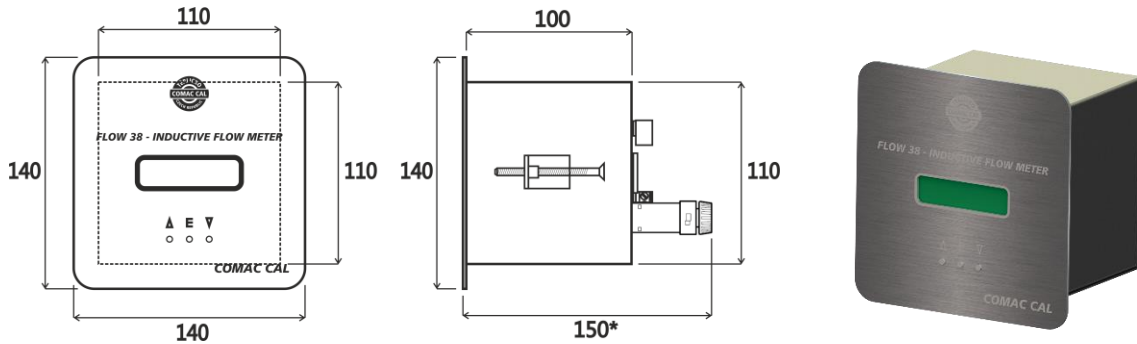

*The necessary mounting depth, including the cable connector from the flow sensor is 200mm.

Meter wiring

The evaluation unit consists of two assemblies:

Front PCB with display unit

Input/Output PCB along with power supply

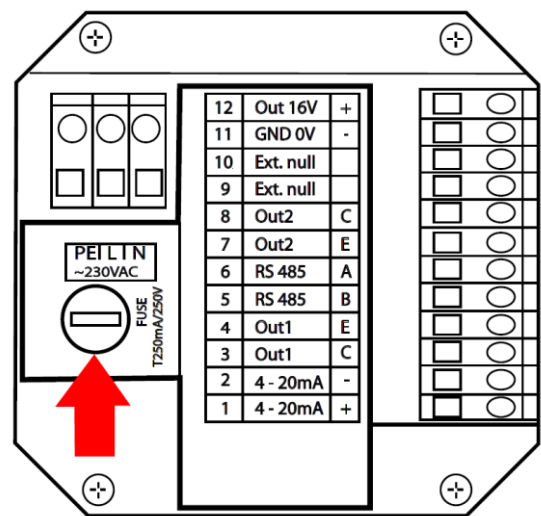
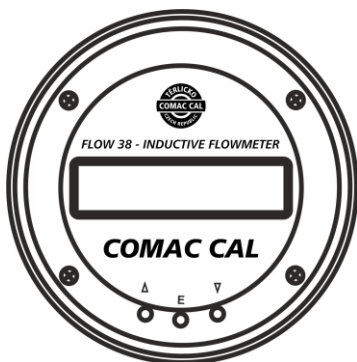

Evaluation unit terminal board wiring:

- Terminals No. 1, 2 current output 4...20 mA
- Terminals No. 3, 4 OUT1-Imp/Flow switch
- Terminals No. 5, 6 RS485 communication
- Terminals No. 7, 8 OUT2-Imp/Flow switch/Status
- Terminals No. 9,10 reset Total V register (resettable counter) by external button
- Terminals No.11,12 output voltage 16 V/100 mA (power supply for changing to active current and impulse outputs)
- Terminals L, N, PE mains voltage 230 VAC (standard), available also in 24 VAC/VDC version which does not matter on the polarity of the power connection. (Install as an independent supply circuit with its own protection 0.5...1 A)

Note: Terminal board and jumper connection is always indicated on the power supply cover sheet and on the rear cover.

OUT1 / OUT2

Impulse outputs / FlowSwitch / Status

OUT1 and OUT2 outputs are freely configurable and implemented by the optocoupler with an NPN switching transistor. Limit parameters of this optocoupler are 80V/50mA/100mW max. The output can be connected as a passive one or active one when terminals 11 and 12 are used. In active mode, the meter makes use of its internal galvanically separated 16V power supply. In this case, the switch voltage for logical high is 16V with the recommended current consumption of approx. 2mA with regard to optocoupler transfer. The output in off-state is found in high impedance state and so it is necessary to use a pull down or pull up resistors for defining the steady-state level.

Configuration:

- 1) The **Impulse** output is used for remote transmission of volumetric impulses. The conversion constant is arbitrarily variable using buttons or user software. The adjustment must be carried in such a manner that the frequency at maximum flow rate $f_{out} < 400\text{Hz}$.
- 2) The **FlowSwitch** is used for flow rate value monitoring. When the set limit flow rate is exceeded, the contact will be switched (contact making/breaking). The level of contact making and contact breaking is different – the contact has hysteresis. The hysteresis is adjustable in %.
- 3) The **Status output** is used for evaluation of meter's status – failure, warning, failure+warning.

Wiring connection examples – passive output:

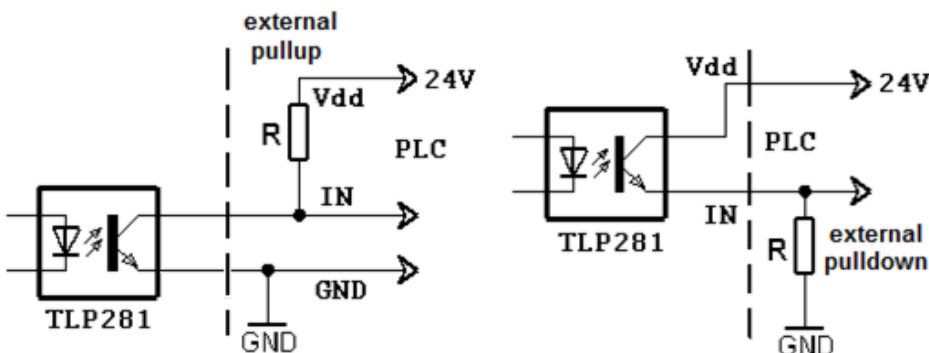

Terminal board wiring connection:

12	Out 16V	+
11	GND 0V	-
10	Ext. null	
9	Ext. null	
8	Out2	C
7	Out2	E
6	RS 485	A
5	RS 485	B
4	Out1	E
3	Out1	C
2	4 - 20mA	-
1	4 - 20mA	+

Examples of connection – active output:

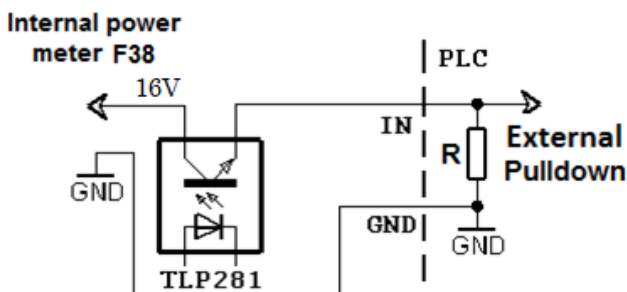

Terminal board connection:

12	Out 16V	+
11	GND 0V	-
10	Ext. null	
9	Ext. null	
8	Out2	C
7	Out2	E
6	RS 485	A
5	RS 485	B
4	Out1	E
3	Out1	C
2	4 - 20mA	-
1	4 - 20mA	+

Due to $CTR \approx 100\%$ and $I_f = 2.5\text{mA}$, it is suitable to select collector current up to 2.5mA.

Current output

D/A - converter of the FLOW 38DNV evaluation unit is 16-bit with data recovery per second. The converter is isolated from the meter by optocouplers.

If the current output is passive, it is necessary to feed the current output from an external power supply. External power supply U_e can be 12...24 V.

The loop resistance must not be higher than $R = U_e / 0,02$ ($\Omega;V$).

As standard, it is set in such a way that with the maximum flow Q_{max} the loop current is 20mA and with the zero or negative flow, the loop current is 4mA. The borders can be set by buttons or user software for all flow directions. In case of loss of power for the meter, it is indicated by 0mA current loop output. In case of active current loop, an internal 16V galvanically isolated power supply is used in FLOW38 meter.

Current loop wiring connection example:

Passive current loop

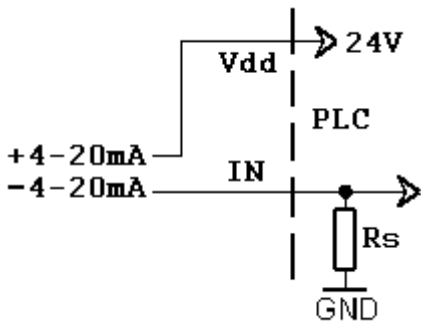

Terminal board wiring connection:

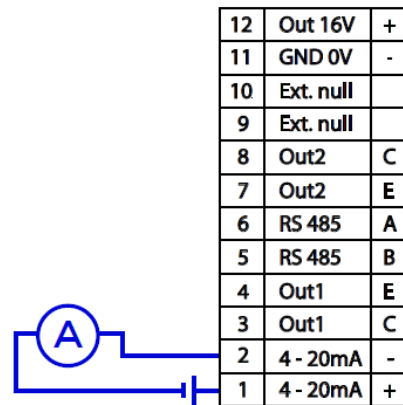

Active current loop

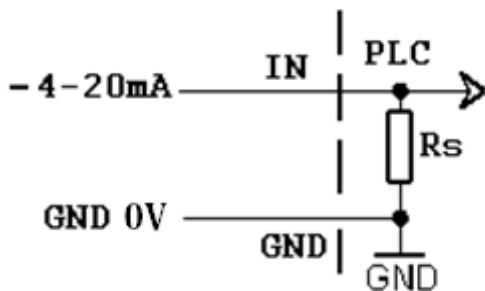

Terminal board wiring connection:

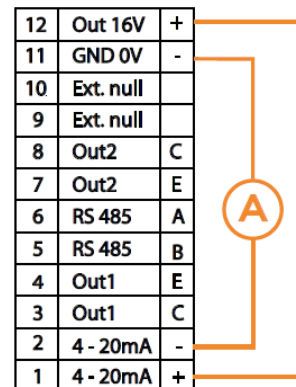

The external button to reset the user volume Vnull

External zeroing (Reset)

Zeroing the user volumetric counter is led out to the external input PIN9 and PIN10. The input is isolated by an optocoupler. It can be managed by an external zeroing button is connected to terminals 9 and 10.

Jumper and terminal board wiring connection:

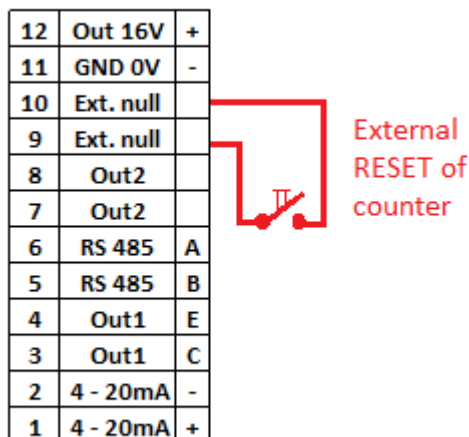

Data output

The meter can also be provided with RS485 communication with M-Bus protocol as per EN 1434-3 or ModBus RTU.

Protection degree

The meters meet all the requirements for IP 65 protection degree. In order to ensure IP 65 protection after installation in the plant or after a service intervention, the following must be met:

- The "O" rings inserted in sealing grooves must be clean and intact.
- If necessary, the "O" rings should be dried, cleaned or replaced with new ones.
- Screw caps must be tightened properly.
- Cables used for connection must have their outside diameters according to cable entries used.
- Tighten the cable entries properly.
- Cables before entering the cable entries should form a loop pointing downwards ("drip loop"). This will eliminate the penetration of moisture into the cable entry. Install the measuring instrument always with cable entries not facing upwards if it is possible.
- Provide all unused cable entries with dummy plugs.
- Do not remove sealing rings from the cable entries.

Replacement of tube fuse in the meter

!!! Risk of electric shock! Uncovered components generate dangerous voltages. Before removing the cover from the electronics area, make sure that the meter is not under voltage!!!

The instrument fuse is on the power supply PCB and it is replaced as follows:

1. Switch off power.
2. Unscrew the rear cover of the meter housing
3. Remove the protective cover and replace the instrument fuse (use solely T250mA tube fuses for 230VAC power or T800mA for 24VAC/VDC power)
4. Proceed in reverse order to recover the function of the meter.

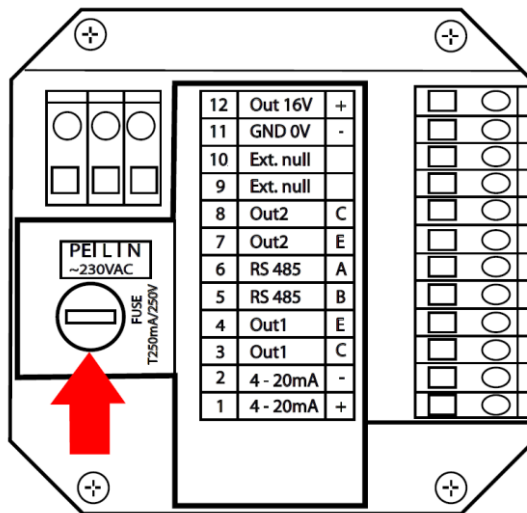

Wiring check

After completion of wiring, it is necessary to check:

- Connecting cables for damage.
- If the cables used are suitable for given cable entries.
- Cables for pull relief.
- Correct tightening of cable entries.
- Correct connection of cables to terminals.
- Whether the supply voltage corresponds with the nameplate data.
- After the meter is closed, tighten the covers properly to the O-rings.

Putting into operation

Prior to connection to power supply, check the device installation accuracy in accordance with “Installation in pipeline“ and “Wiring” chapters.

If you wish the meter to take measurement as precisely as possible right after powering up, it is a good idea to fill the flow sensor with water, one or two days before its installation, so that all of its electrodes are flooded. Just before the installation, the water is discharged and the sensor is installed into piping. Right after installation, piping is filled with a medium so that the electrodes cannot dry off.

If the meter has no electrode for empty tube detection, do not connect the meter to power before filling the system with the fluid to be measured and power off the meter before system discharge.

Once the meter is powered up, the green LED on the front glazed panel is lit, confirming the supply voltage on the control PCB and stabilization of parameters of the meter takes place subsequently. The stabilization is indicated on the meter's display. After that period of time, the meter starts measuring.

Meter status:

It is displayed continuously on the screen as one of the main menu items and in case of a non-standard state or a failure, this is displayed by alternating indication of the status and main menu basic data and the operator is warned by a text. The meter status is divided into 4 basic groups:

- 1) OK everything is all right
- 2) Warning – the meter takes measurement but some of the parameters are out of range
- 3) Error critical error – the meter does not take measurement
- 4) Empty tube if the EMPTY TUBE TEST function is activated

Flow direction:

The arrow indicates the direction liquid flow inside the sensor and thus the correct orientation of the meter's sensor for installation in piping. In case of inversely performed installation, it is possible to toggle the direction in electronics between positive/negative and thus avoid incorrect value imaging and reading out .

Basic parameter settings

The meter or flow meter parameters are set by the manufacturer in accordance with the purchase order. If these values are not indicated in your purchase order, the meter will be set up using the default parameters in accordance with the meter's range. The operator can make modifications by means of three buttons on the meter's panel or through the RS485 interface.

Safety rules for operator

Any interventions in the inductive flow sensor and evaluation unit itself are illegal on the part of operator and they may lead to direct scalding by medium. Perform electrical connection always after powering off.

FLOW 38DNV OPERATING INSTRUCTIONS

Basic button functions

The meter is provided with two external buttons on the side of the electronics housing and with three internal buttons on the bottom of the measuring electronics PCB which is accessible after unscrewing the front glazed cover.

Settings menu is enabled by a long press of the middle button (**E**) under the cover glass. A long press of the upper button on the lateral face of the display unit or a long press of the left (**▲**) button under the cover glass have the same function.

Listing in menu can be carried out either with the lateral buttons or with interior buttons after removal of the upper cover glass. The function of lateral buttons is identical to that of outer buttons under the cover glass.

The **LEFT BUTTON** is used for listing in menu upwards (**▲**), after a long press, you will go over to settings menu. In settings menu, it is used to increment a value.

The **RIGHT BUTTON** is used for listing in menu downwards (**▼**), a long press is used to exit from setting menu. In settings menu, it is used to decrement a value.

The **MIDDLE BUTTON** – a long press makes it possible to go over to settings menu; in settings menu, it is used to confirm the value (ENTER - **E**).



Special button functions

A long double press of the outer buttons activates REBOOT (flow meter reinitialization).

A long triple press of the inner buttons initiates service communication interface. After initialization, you will be asked for entering a password. If the password is not entered, the service interface will be available for reading only.

Setting menu can be exited by a long press of the lower button on the lateral face of the display unit or by a long press of the right button under the front glass. Besides, you can wait for TimeOut to return the flow meter to its basic menu.

Password setting

FLOW38 meters have two levels of password, namely a user password and a production password.

USER PASSWORD makes it possible to change user parameters that have no influence on calibration of the meter. It is a user configurable password whereas the default password value is 0000. The password is required only at the first entry and it will become invalid after returning to basic display or within two minutes of inactivity when the meter returns again to its basic display automatically.

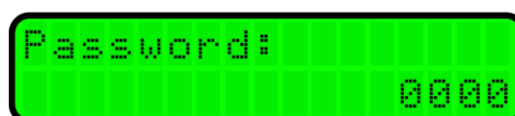

PRODUCTION PASSWORD is a generated, unique password linked with the given meter which is not publicly accessible. Data can only be modified under the production password an authorized person entrusted by COMAC CAL s.r.o.

These are the following data:

Serial number
*k*1-constant
*n*1-constant
 Sensor – DN

Basic menu

Basic display menu contains the following items:

NAME	INDEX
Date and Time	-
Flow rate	Q
Flow bar graph	»
Volume (+)	+V
Volume (-)	-V
Total volume	Σ V
User volume	rV
Status	-

The order may vary as per meter's settings The customers may select the data to be displayed on the first two lines (or change the order) in such a manner that corresponds to their requirements.

E.g.:

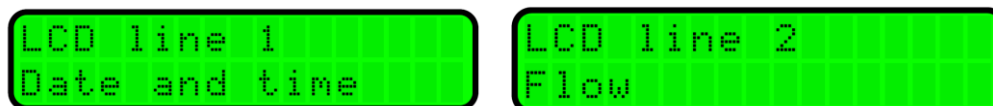

In case that the meter's status is found in a different than normal and correct (OK) status, measurement failure indication alternates with the normal display indication. As a consequence, it is not necessary to check the status all the time; in case of trouble, it is indicated on the display unit automatically.

Examples of representation in normal status according to user settings:

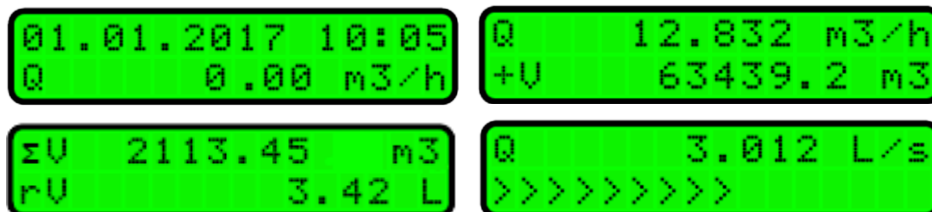

Note: The order of representation of menu items can be modified by user according to the customer's needs.

Flow meter settings

The meter can be reconfigured in Settings menu. In the case of first requirement for reconfiguration (E-button is pressed), the user is asked for password insertion. If the password is valid, it is possible to reconfigure individual items until the user exits Settings menu. The default value for user password is 0000. All modifications need to be confirmed prior to new saving.



```
Confirm changes
Parameter?    YES
```

*Note: Some modifications may not be valid right after saving but these will become valid after reinitialization of the meter - refer to special button functions – REBOOT

Date and time

This menu item is in DD/MM/YYYY HH/MM formats.



```
Date and time
21.07.2017  17:46
```

Use the **▲** and **▼** buttons to set the menu item on the display and press the **E** to edit. Implement settings in a standard way, using the setting buttons and confirm by pressing the **E** button.

It is necessary again to confirm the change.



```
Confirm changes
Parameter?    YES
```

Operation time counter

The counter registers the operation time of the meter (switching on). The first line indicates the date when the last counter reset was performed and the second line indicates the length of operation in days, hours and minutes.

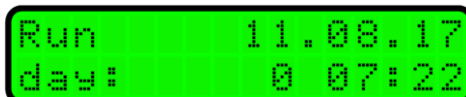

```
Run      11.08.17
day:     0 07:22
```

This counter can be reset by pressing the **E** button when necessary.

Power loss counter

The counter registers the time of loss of power time for the meter. The first line indicates the date when the last reset of power loss counter was performed and the second line indicates the length of time when the meter was out of operation in days, hours and minutes. The counter can be reset again by pressing the **E** button.

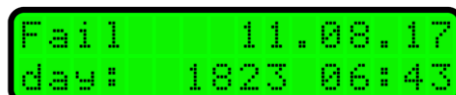

```
Fail     11.08.17
day:    1823 06:43
```

OUT1 and OUT2 outputs

OUT1 can be configured as the impulse output or Flow Switch contact. OUT2 can be set as the impulse output, flow switch or status contact.

1) OUT1 setting

Impulse output

In impulse output parameter setting, it is possible to change the logics (polarity) of the electrical signal (on-state/off-state), furthermore, to set the impulse output to which direction the volumetric counter will respond (volume run in positive direction, in opposite direction and in both directions) as well as your own impulse constant, including its indication (imp/L or L/imp) and impulse width.

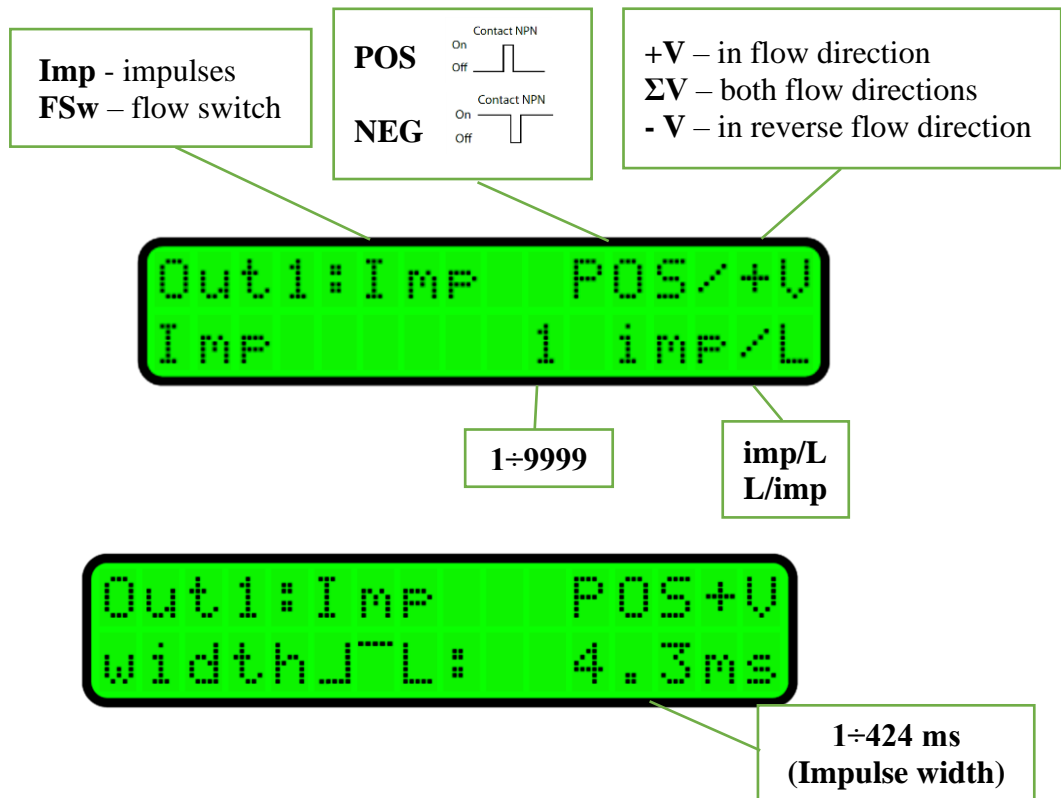

*Note

Period [ms] = pulse width [ms] + inter-pulse gap [ms] where gap ≥ width

The pulse width is selected in steps by scrolling through predefined values with ▲ or ▼ buttons.

Flow switch operation

In “flow switch” status output parameter setting, it is possible to change the logics (polarity) of the electrical signal (on-state/off-state), furthermore, to set the output to which direction the output will respond (flow in positive direction, in opposite direction and in both directions) as well as your own switching point value.

*Qlimit - the number of decimal places is given by DN of the given meter and cannot be changed.

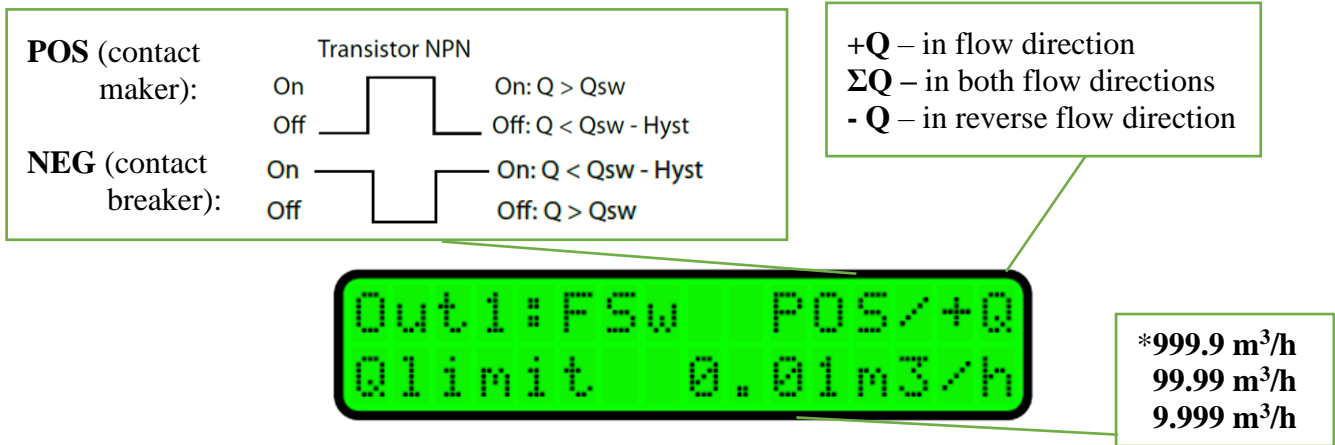

The status contact makes it possible to set the amount of hysteresis between Qon and Qoff states



2) OUT2 setting

Impulse output

For complete setting the parameters of impulse output, it is possible to change the logics (polarity) of the electrical signal (positive/negative), to set the impulse output to which the volumetric counter will respond (volume run in positive direction, in opposite direction and in both directions) as well as your own impulse constant, including its indication (imp/L or L/imp).

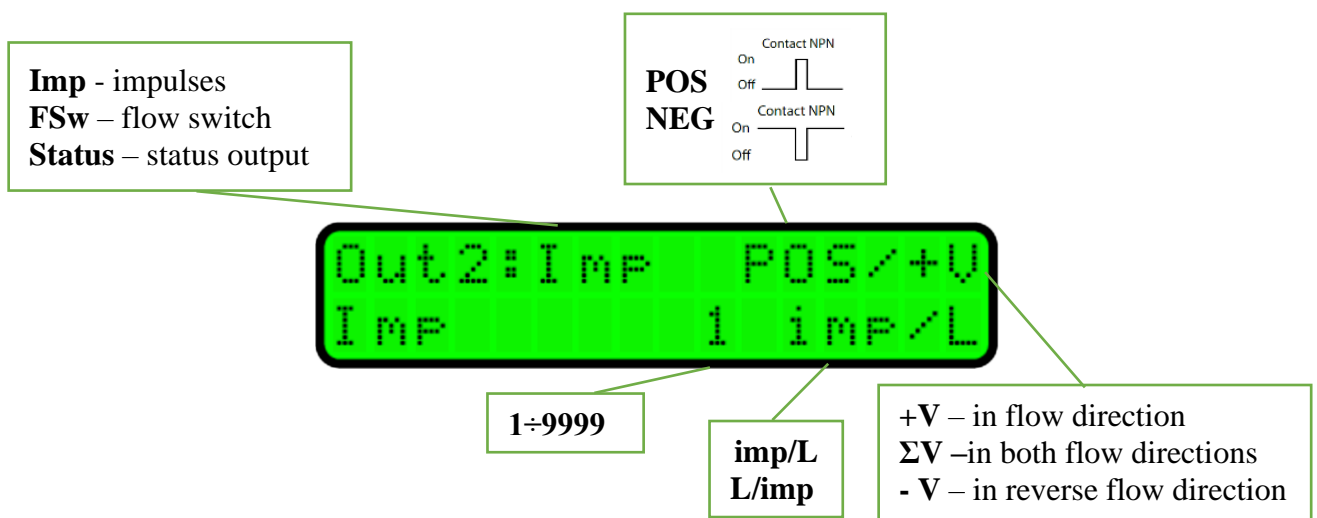



1 ÷ 424 ms
(Impulse width)

*Note

Period [ms] = pulse width [ms] + inter-pulse gap [ms] where gap ≥ width

The pulse width is selected in steps by scrolling through predefined values with ▲ or ▼ buttons.

Flow switch operation

In “flow switch” status output parameter setting, it is possible to change the logics (polarity) of the electrical signal (on-state/off-state), furthermore, to set the output to which direction the output will respond (flow in positive direction, in opposite direction and in both directions) as well as your own switching point value.

*Qlimit - the number of decimal places is given by DN of the given meter and cannot be changed.

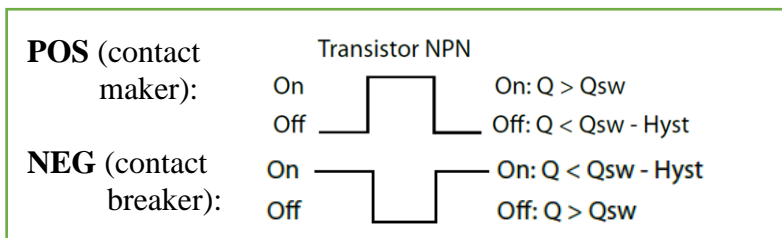

+Q – in flow direction
ΣQ – in both flow directions
- Q – in reverse flow direction



*999.9 m³/h
99.99 m³/h
9.999 m³/h

The status contact makes it possible to set the amount of hysteresis between Qon and Qoff states.

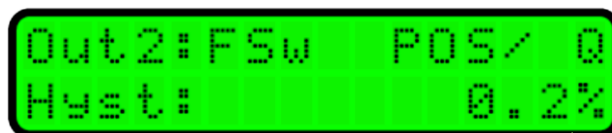

0.1 ÷ 99.9 %

Meter status – error output

Output 2 compared to Output 1 can be set additionally as a failure status output of the meter. If no failure status occurs in the meter, the status output is on-state.

```
Out2:All
Meter status
```

Error – service is always required
Warning – setting is out of parameters
All – warnings + errors

Current output

In current output parameter setting, you can set up the flow direction to which the current loop should respond, to change the limits of current loop for 4mA, 20mA and possibly to perform calibration of this current loop.

```
Loop 4-20mA ±Q
4mA: -50.00m3/h
```

Number of significant digits: 6

±Q – both flow directions (0 l/h = 12mA)
+Q – positive flow direction
ΣQ – both flow directions (abs(Q))
- Q – negative flow direction

```
Loop 4-20mA ±Q
20mA: -50.00m3/h
```

Number of significant digits: 6

±Q – both flow directions
+Q – positive flow direction
ΣQ – both flow directions
- Q – negative flow direction

Current loop calibration can be carried out by changing the Offset value.

```
Offset 4-20mA
+ 0uA
```

+ = calibration to positive values
- = calibration to negative values

0÷99

Communication

If the flow meter is ordered with communication, it is possible to choose either MODBUS-RTU or MBUS protocols. RS485 is the physical layer of both protocols. In MODBUS-RTU protocol, it is possible to set parity and the number of stop bits. The parity of MBUS protocol is fixed to EVEN and the number of stop bits to 1. Due to the existing requirements for MBUS protocol and MBUS physical layer, it is necessary to use an interior expansion card. In this case, besides parity and stop bits, the transfer rate is fixed to 2400Bd as well.

The flow meter address can be in the range of 0 – 255. The MBUS protocol supports the broadcast address 254.

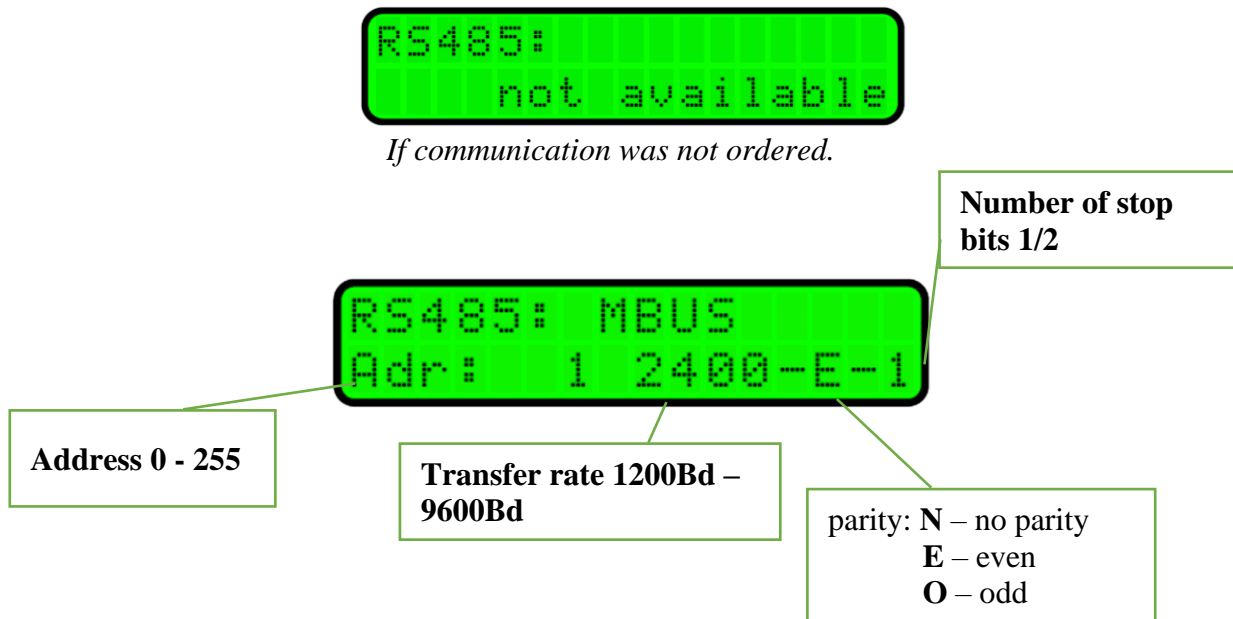

Idle state basic indications on display

Basic indications in idle state can be influenced and modified in such a manner that the data needed by the user can be found on the first two lines on the display. Whereas the order of the other items is retained. If you want to change a setting, press the **E** and **▲** or **▼** buttons and select the data on the line which is then confirmed by the **E** button. The customer can select from these indications, namely both on the first and the second lines.

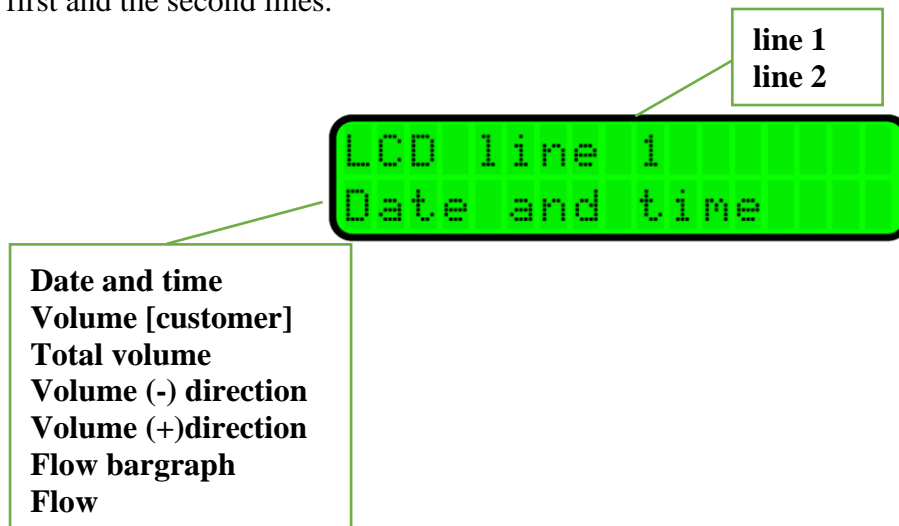

Flow rate damping

Time averaging of flow rate values within the range is set here. Averaging is used both for the display unit and the current loop.

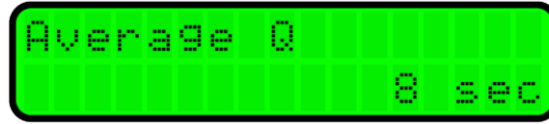

0÷29

Display backlight

Here, you can set the period during which the display backlight is turned off after the last activation of a button. Use the \blacktriangle and \blacktriangledown buttons to select the desired settings from menu.

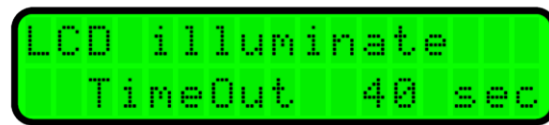

- 40 sec
- 20 sec
- 10 sec
- off
- permanent

Serial number

The serial number is registered in the factory and cannot be changed by user. Modifications can only be carried out by an authorized person under production password.

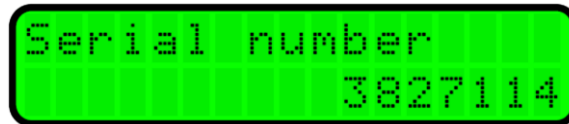

Calibration constants

Calibration constants are registered during the production and cannot be changed by user. Modifications can only be carried out by an authorized person under production password.

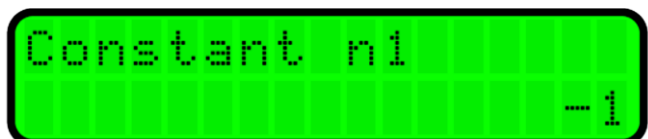
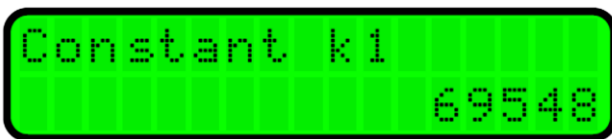

Empty tube test

Activates and deactivates monitoring of measuring tube filling. If the meter was ordered without the testing electrode, the flooding test cannot be activated.

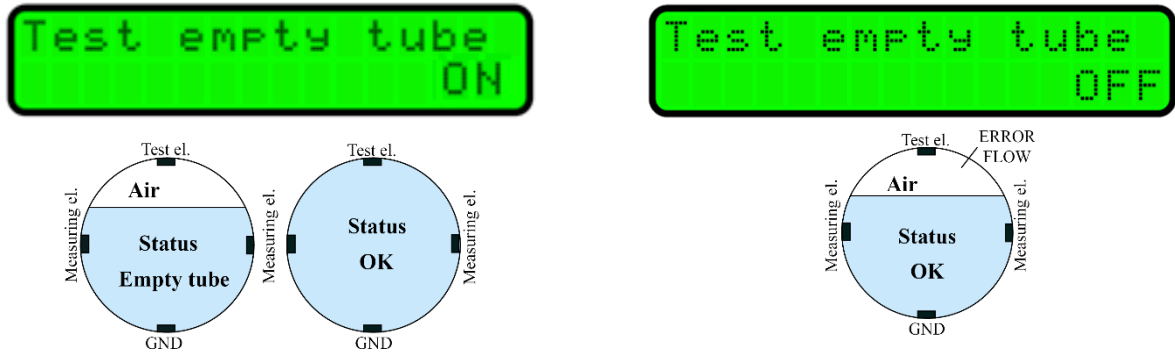

Firmware version

The firmware version is registered in the factory and cannot be changed by user.



Dead band – measurement of start suppression

Star of measurement is registered in the factory and cannot be changed by user. Modifications can only be carried out by an authorized person under production password.

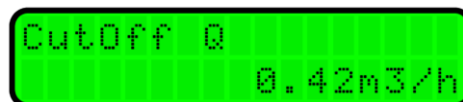

Zero calibration

The date under "Zero calibration" heading indicates the date when zero flow calibration was performed.

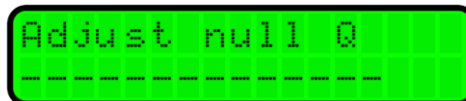

If you want to recalibrate the zero flow, press the **E** button. The flow meter evaluates the measured data automatically and if YES is set, upon confirmation of the selection by the **E** button, a new value for zero flow will be set and the date of the last recalibration is updated (when NO is selected, the value for recalibration is not registered and everything remains in original setting).

Note: Before recalibration is performed, do not forget to close the valves first and secure a real zero flow (stationary medium) in the system.

Flow simulation

Flow simulation serves for comfortable setting and checking the systems in which the flow meter is installed without necessity to use realistic flow of medium through the meter and without necessary installation of the meter in the pipeline. The display shows the simulated flow and current and impulse outputs of the meter correspond to this data. Such a simulated flow is not recorded in volume invoice registers, the control can be carried out in user resettable volume register **rV**.

WARNING! If the meter runs in simulation flow mode, it does not return automatically after two and a half minutes as it is typical for all other modes and representations. After termination of flow simulation mode, it is necessary to exit Parameters menu by the (\blacktriangledown long press >3sec) button!!!

The customer can set the value of the simulated flow. If you want to activate or deactivate the simulation, press the **E** button.

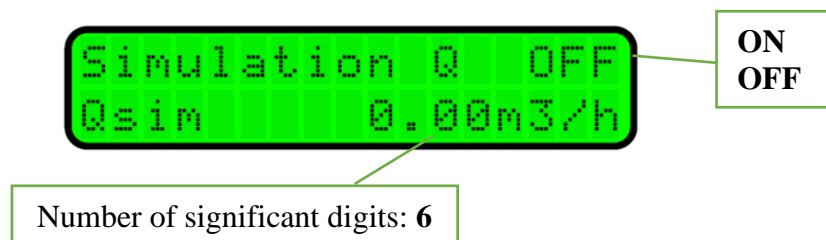

Language

If you want to change the meter's language, press **E** and then select a desired language from menu.



Counter resetting

Here, it is possible to reset all or only certain volumetric counters. If you want to perform resetting, press **E** and select which counter you wish to reset (ΣV , -V, +V or all). After resetting, the date when the last reset was performed is displayed and which counter was reset (again, ΣV , -V, +V or all).

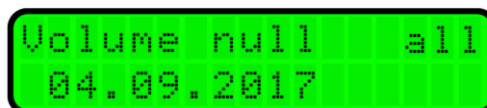

Nominal diameter (DN)

This parameter is set in the factory and cannot be changed. DN modification can only be carried out by an authorized person under production password.



Flow direction

Specifies the direction of flow in the flow sensor with respect to the data in electronics. Positive direction is the flow in the sensor identical to the arrow indicated on the meter's name plate. If the medium flows through the sensor against the arrow on the sensor, select the NEGATIVE direction.

If you wish to make the change, press **E**.



Flow direction
Positive

Signal saturation filter

The setting determines the behaviour of the input amplifier during saturation. Saturation can occur if the properties of the medium change abruptly or if there are impurities in the medium.



Amp. saturation
filter 10sec

10sec
OFF

OFF – the meter will declare an error as soon as the input amplifier becomes saturated

10sec – the meter will replace the erroneous flow rate value due to saturation by the one right before saturation; this flow rate value is held for 10sec max. If the amplifier fails to return to normal state within 10sec, the error – Amp. signal limit is declared.

Instead of the flow index Q indicated on the display, the symbol “H” - hold is indicated.

Flow units displayed [Q]

If you wish to change the way of flow indication, press **E**. Use the \blacktriangle and \blacktriangledown buttons to set the required number of decimal places and by confirming with **E**, go to setting the flow unit representation.

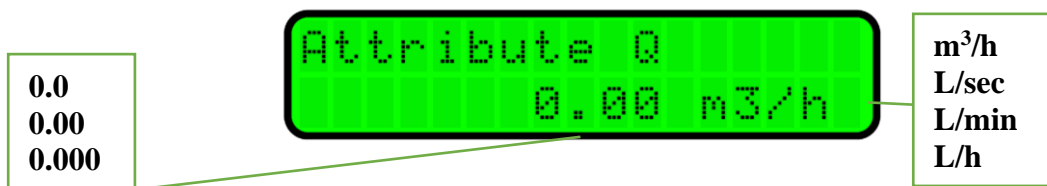

Attribute Q
0.00 m³/h

0.0
0.00
0.000

m³/h
L/sec
L/min
L/h

Q displayed in per cents (Bar graph)

It allows you to set the maximum flow Q for full representation of horizontal line graph. This is formed by 16-character segments >> or << according to direction in which the medium flows (in case of selection of - Q or Σ Q only). This is illustrated also by the beginning of the graph either from left side (positive direction of flow) or from the right side (negative direction of flow).

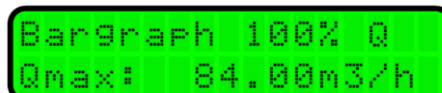

BarGraph 100% Q
Qmax: 84.00m³/h

Volume units displayed [V]

To change the way of volumetric indication (+V, -V and ΣV), press **E**. The number of decimal places for the volumetric counters can be selected from 3 to none. Furthermore, the selection of units is here (L, m³). If these parameters are changed, the respective measured value will be changed as well. In consequence, we recommend resetting of the counters changed in this way after reconfiguration.

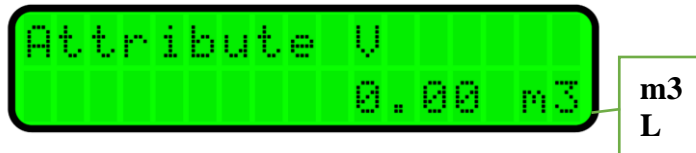

User counter with reset option

It is the volumetric counter (rV) available to user who can reset it using external control buttons (simultaneously \blacktriangle and \blacktriangledown). The number of decimal places can be selected from 3 to none. Furthermore, the selection of units is here (L, m³). If these parameters are changed, the respective measured value will be changed in this counter as well – the value is not recalculated. In consequence, we recommend resetting of the counter changed in this way after reconfiguration.



Password change

The password for modification of the customer parameters is set by default to **0000**. However, the user can change it in this window by pressing **E**. The access code must have 4 digits.

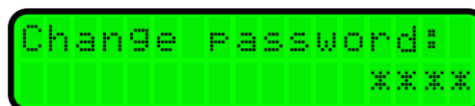

Default settings (original factory settings)

During activation of this function, the configuration of the meter will be restored to the factory default state in which it was shipped. All settings carried out by the user will be cancelled and all volumetric counters will be reset.

The user password is cancelled and the access password is reset to original (0000). At the same time, the calibration constants will be set to the factory values. Before activating this function, it is useful to record or make a data backup of all counters.

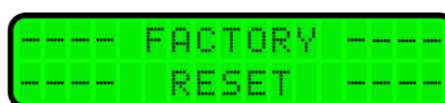

Expansion module

The FLOW 38DNV can be fitted with an expansion module for enhancement with the following function:

- 1) DATALOGGER
- 2) MBus
- 3) DATALOGGER + MBus

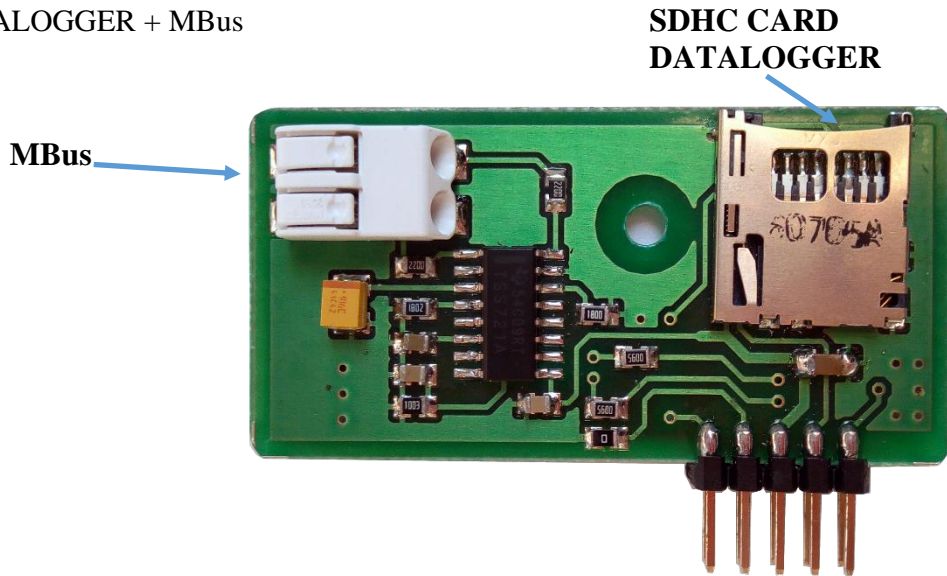

The expansion module is inserted in the slot found in power supply part of the meter and it is attached with an M3 screw.

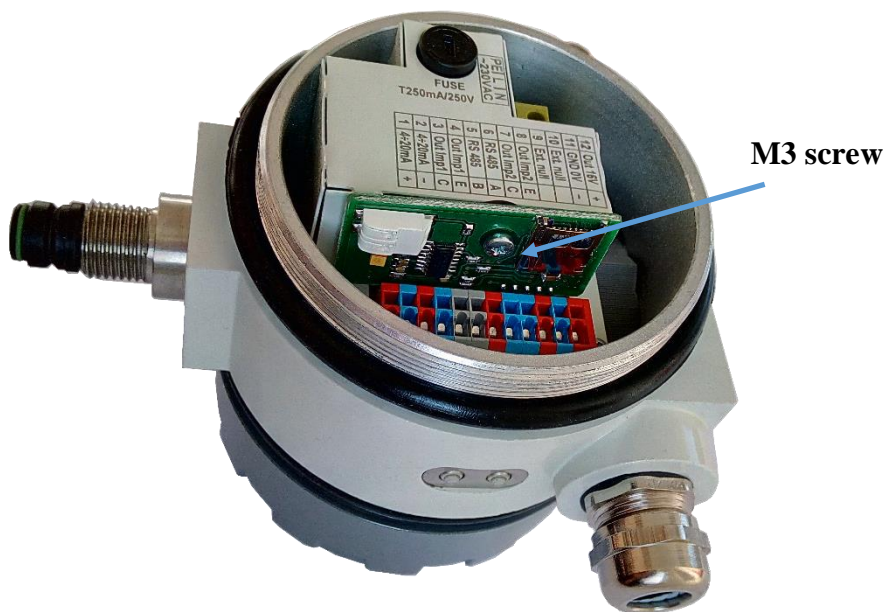

1) Datalogger

Power off and insert the expansion card into the available slot and fix it with an M3 screw.

Insert the prepared microSDHC card in the module after power on. After insertion, DATALOGGER is created in SET menu of the meter automatically.

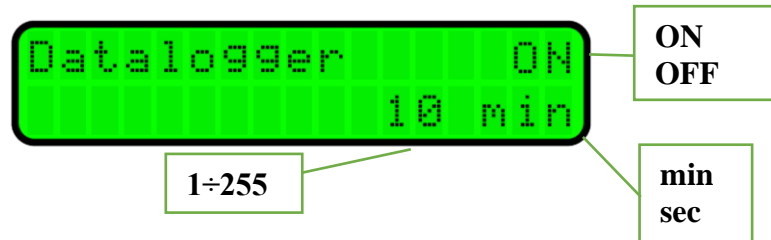

If the meter fails to switch to DATALOGGER menu after insertion, find out this item in SET menu. Now you can set logging activation/deactivation and logging interval. Available units for the logging interval are minutes or seconds.

If the card is accepted and there is a log file at the same time, the end of file is searched out and the data will be added at the end of this file. While the end of file is searched, the number of searched and occupied clusters is indicated in the left lower corner. The number of clusters in a file for searching is limited to 4096 (2MB). If the log file is longer, a new one is established, incremented by 1.

The log file name is LOG00.TXT-LOG99.TXT

In the case of correct data write, WRITE is always indicated in the left lower corner for a moment.

If the microSDHC card is not accepted after logging is activated, an error message is displayed:

E:1 - GO_IDLE_STATE
E:2 - SEND_IF_COND
E:3 - ACMD41
E:4 - READ OCR
E:5 - no SDHC card

Requirements for microSDHC card:

- 1) The card must be **SDHC** type (cards with 4GB capacity and more)
- 2) File format must be **FAT32**
- 3) Cluster size must be **512B***

*Note

Cards larger than 2GB cannot be normally formatted to 512B clusters, so the card must be split into two partitions where an active partition must always be lower than 2GB, formatted to FAT32 with 512B clusters.

The formatted card can be bought as accessory to the expansion module.

2) MBus

Power off and insert the expansion card into the available slot and fix it with an M3 screw.

After power off, connect the MBus communication line to terminals of the expansion module.

Communication parameters:

2400Bd

paEven

8 data bits

1 stop bit

*Address: last two digits of the serial number

*If RS485 communication is enabled, the module address with a software version 8.228 and higher is the same as the set address in this communication.

Diagnostics

Reception and transmission can be diagnosed in SET menu, communication line 1 - RS485 settings.

Rx - reception on line 1 (RS485, MBus/Modbus)

Tx - transmission on line 1 (RS485, MBus/Modbus)

R1 - reception on line 2 (MBus expansion module)

T1 - transmission on line 2 (MBus expansion module)

Turning the FLOW 38DNV display

User adaptation

The measuring element makes it possible to turn the display according to installation of the meter. To change the position of the display, it is necessary to unscrew the top cover of the meter with the glass window. After slackening four fixing screws (see figure below), it is possible to turn the plastic cover along with the electronics PCB $3x \pm 90^\circ$ at the most. While turning, pay particular attention to connection cables with the power supply part which is attached to the rear side of the meter's head.

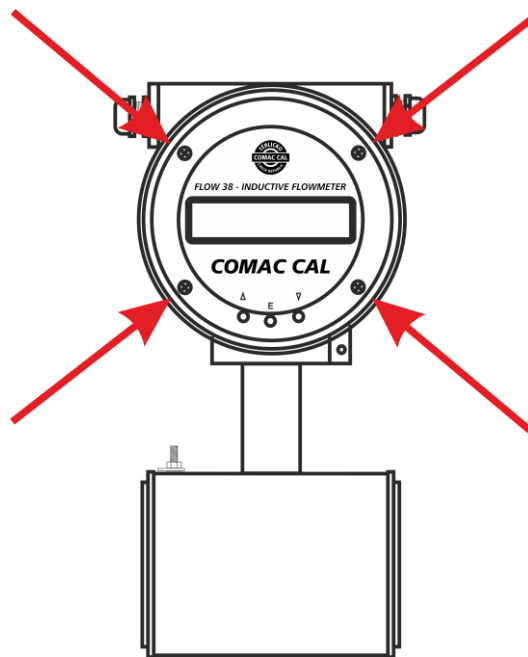

Procedure to turn the display board to the required position

1. Unscrew the front cover with the glass window.
2. Unscrew four fixing bolts.
3. Turn the plastic cover with the electronic display board to the required position (3x by $\pm 90^\circ$ maximum).
4. Screw in the four fixing screws. *Make sure that the screws are tightened properly!!!*
5. Screw in the front cover with the window.

Disassembly and assembly of PCB

Power supply and terminal board PCB

Recommendations

Before replacing the power supply PCB due to its malfunction, we recommend you to check the instrument fuse and replace it if necessary (page 22).

Warning:

- Risk of electric shock
- Before removing the rear cover (cap) for the electronics, make sure that the power is off

1. Unscrew the rear cover of the meter's housing.
2. Disconnect the connected cables and if necessary, take them out of the cable entries.
3. Unscrew the four screws holding the power supply cover sheet along with the PCB.
4. Pull the power supply PCB, including the cover sheet a little out and disconnect the flat cable connector carefully.
5. Pull the power supply PCB out of the electronics cover and replace it with a good one, possibly use the PCB with another version of the power supply.
6. Connect the flat cable connector and insert the PCB in the electronics cover in proper orientation.
7. Using four screws, fix the PCB with cover sheet to the evaluation unit box.
8. Reconnect the cables and screw in the instrument housing cap.



Display PCB – replacement

1. Unscrew the front cover with the glass window.
2. Unscrew four fixing bolts.
3. Remove the original electronic board including the plastic cover and disconnect carefully the flat cable connector and the button connector.
4. Disconnect the sensor conductors from terminals.
5. Connect the sensor conductors to the terminals of the new board.
6. Reconnect the button connectors and flat cable connector.
7. Turn the electronic PCB with display to the required position ($3x \pm 90^\circ$ maximum).
8. Screw in the four fixing screws.
Make sure that the screws are tightened properly!!!
9. Screw in the front cover with the window.



Technical data

Evaluation electronics technical parameters

Supply voltage:	110...230V AC (+10; -20%) 50...60Hz (standard) 24V AC/DC with reverse polarity protection (per order)
Input power:	4.6VA
Display:	LCD 2 x 16 characters, backlit
Size	DN 4...600
Lining material	Rubber (hard, soft, certif. for potable water): DN25...600 (up to 70°C) PVDF: DN4...DN20 (up to 145°C), Rilsan: DN 25÷DN 600 (-10°C ... 70°C) PTFE: DN 10...DN 80 (up to 120°C) ETFE: DN100...600 (up to 150°C), PFA (on request): (up to 130°C), Ceramics (on request): DN 15...DN80 (up to 150 °C)
Electrode material	CrNi steel DIN 1.4571, Hastelloy C4, Titanium, Tantalum
Construction	All-welded frame
Sensor material	flanged – stainless steel and structural steel with polyurethane coating sandwich, threaded, food processing – stainless steel
Process connection	sandwich flanged DIN (EN1092) threaded (EN 10226-1) food processing (fittings DIN 11851), clamp(DIN32676)
Measuring range (Qmin/Qmax)	0.2...12 m/s (1/60); 0.12...12 m/s (1/100); 0.06...12 m/s (1/200)
Flow meter accuracy	up to 0.5 % (for 0.1...10 m/s)
Repeatability	up to 0.2 % (for 0.1...10 m/s)
Additional electrodes	reference, earthing and detection for empty pipeline (DN 10...DN 600)
Empty pipeline detection	DN 10...DN 600
Min. conductivity of medium	20 µS/cm (at a lower conductivity upon agreement with manufacturer)
Displayed values:	flow – m ³ /h; L/h; L/min; L/s; positive, negative volume – m ³ ; L; positive, negative, sum in both directions
Controls	2× external button (value viewing) 3× internal button (viewing + parameter modification)
Inputs:	User counter reset
Outputs	impulse/flowswitch (max. 400 Hz), 4...20 mA (pulse and current outputs are passive with an option of feeding from meter's internal power supply)
Communication:	RS485 (M-BUS/Mod-Bus protocol), MBus, microSDHC card
Sampling:	12.5 samples per second
Display response:	1.28 s
I/O response:	1.28 s (current loop)
Type of electronics	head (H – standard)
Design	compact, detached (standard cable length 3 m)
Pressure loss	negligible
Pressure	PN10, PN16, PN25, PN40, PN64, PN100
Cable entries	LH (mains) 1 x cable max.φ 13 mm RH (outputs) 1 x cable max.φ 13 mm
Ambient temperature	5...55°C
Ambient humidity	max. 90%
Head size	144 x 151 x 125 mm (H x W x D), φ head 104 mm

Weight	1340 g (evaluation unit in detached version)
Material	Al cast – powder coating, design PANEL - SS304
Max. ambient temperature	55 °C
Flow sensor protection	IP65, IP67, IP68
Electronics protection	design HEAD – IP65

If you do not find your size or structure in the Flow sensor technical parameters Table, it is a special or non-standard design. In this case, find the information on the sensor nameplate where this information is always indicated, or please contact the manufacturer for more detailed information.

Error limits at reference conditions (range 1:1000)

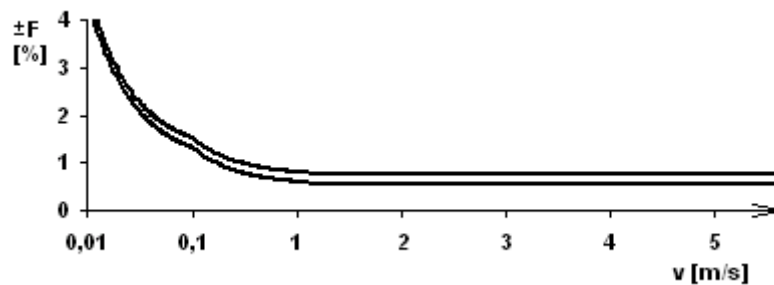

Diameter nominal	Measured value maximum error			Curve
	v ≥ 1 m/s	1 m/s > v ≥ 0.1 m/s	v < 0.1 m/s	
DN [mm]				
≤ DN 10	0.8 % z M*	0.72 % + 0.8 mm/s	1.52 % + 0.35 mm/s	1
≥ DN 15	0.5 % of M*	0.52 % + 0.8 mm/s	1.22 % + 0.35 mm/s	2

* Of M – of the measured value

Factory settings

The current loop is set in such a manner that 4 mA corresponds to zero flow and 20 mA corresponds to its maximum value.

The address of the meter is set to 1 by default and communication parameters to 2400Bd,8db,1sb,parity EVEN (Mbus) or 9600Bd,8db,1sb, no parity (Modbus).

Access password (PIN) for parameter changing is always set to **0000** and this value will be reset in case of restoring to factory default settings.

Impulse constants and current loop – factory settings

Diameter nominal DN	Impulse output		4 – 20mA (in Qmin/Qmax 1/100 range)	
	Vout[imp/l]	Vout - pulse width [ms]	Q[l/h] for 4mA	Q[l/h] for 20mA
4	10	4	0	600
6	10	4	0	1,200
8	10	4	0	2,200
10	10	4	0	3,400
15	10	4	0	7,600
20	10	4	0	14,200
25	10	4	0	21,000
32	1	4	0	34,000
40	1	4	0	54,000
50	1	4	0	84,000
65	1	4	0	144,000
80	1	4	0	220,000
100	0.1	4	0	340,000
125	0.1	4	0	534,000
150	0.1	4	0	760,000
200	0.1	4	0	1,350,000
300	0.1	4	0	3,052,000
400	0.1	2.5	0	5,400,000
500	0.1	2.5	0	8,480,000
600	0.01	2.5	0	12,200,000

Diameter nominal	Resolution V	Resolution Q
DN≤25	V [0.001 m3]	Q [0.001 m3/h]
80≥DN>25	V [0.01 m3]	Q [0.01 m3/h]
DN>80	V [0.1 m3]	Q [0.1 m3/h]

Table with flow ranges for individual DN sizes

Diameter nominal [mm]	Qmin [m3/h] as per Qmin /Qmax			Qmax [m3/h] (12 m/s)
	1/60 (0.2 m/s)	1/100 (0.12 m/s)	1/200 (0.06 m/s)	
DN 4	0.01	—	—	0.6
DN 6	0.02	—	—	1.2
DN 8	0.04	—	—	2.2
DN 10	0.06	0.034	—	3.4
DN 15	0.13	0.076	—	7.6
DN 20	0.24	0.142	0.071	14.2
DN 25	0.35	0.21	0.105	21
DN 32	0.6	0.34	0.17	34
DN 40	0.9	0.54	0.27	54
DN 50	1.4	0.84	0.42	84
DN 65	2.4	1.44	0.72	144
DN 80	3.6	2.2	1.1	220
DN 100	5.6	3.4	1.7	340
DN 125	8.9	5.34	2.67	534
DN 150	13	7.6	3.8	760
DN 200	23	13.5	6.75	1350
DN 250	35	21.1	—	2115
DN 300	51	30	—	3050
DN 350	70	41	—	4150
DN 400	90	54	—	5426
DN 500	141	—	—	8480
DN 600	203	—	—	12200

Basic sensor sizes

Threaded design

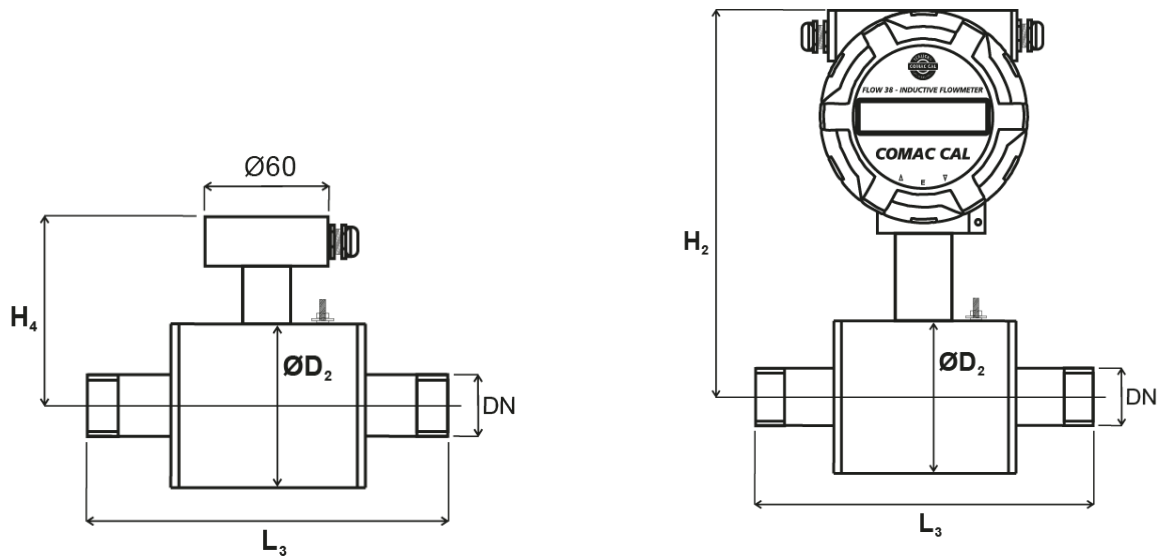

Diameter nominal [mm]	Threaded connection	D ₂ Outside diameter of sensor	L ₃ Building length of sensor	H ₄ Building height of sensor	Weight of detached flow sensor (kg)	H ₂ Building height of comp. meter	Compact flow meter weight (kg)
4	½"	70	157	92	4	182	5
6	½"	70	157	92	4	182	5
8	½"	70	157	92	4	182	5
10	¾"	70	186	90	4	177	5
15	½"	70	190	90	4	177	5
20	¾"	80	200	95	4	182	5
25	1"	90	200	100	5	187	6
32	1 ¼"	100	228	105	5	192	6
40	1 ½"	116	248	113	6	200	7
50	2"	136	258	123	6	210	7

The Table is for PN25.

Sandwich (Inter-flanged) design

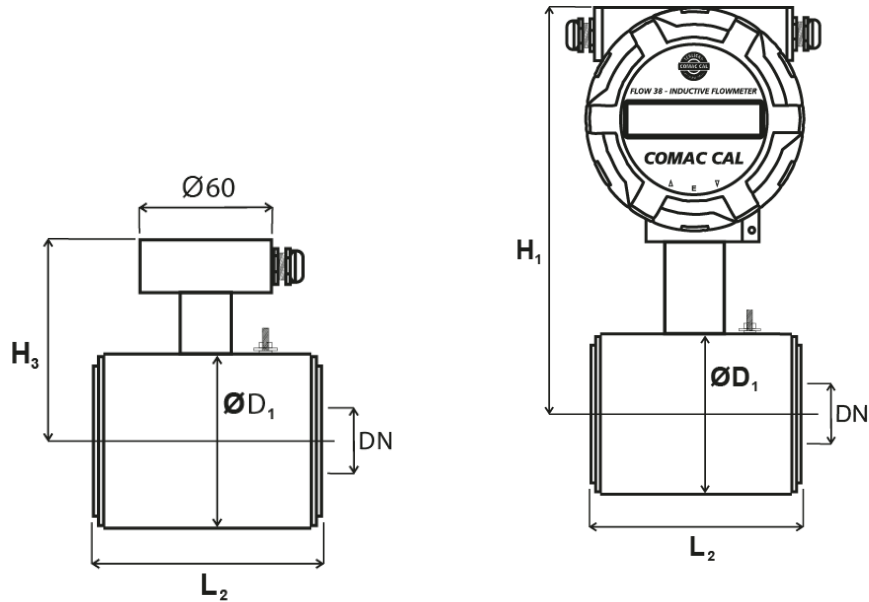

Diameter nominal [mm]	D ₁ Outside diameter of sensor	L ₂ Building length of sensor	H ₃ Building height of sensor	Weight of detached flow sensor (kg)	H ₁ Building height of comp. meter	Compact flow meter weight (kg)
10*,15	51	90	110	2	195	3
20	61	90	120	2	205	3
25	71	90	130	3	215	4
32	82	90	140	3	226	4
40	92	110	150	4	236	5
50	107	110	165	4	251	5
65	127	130	185	5	271	6
80	142	130	200	6	286	7
100	168	200	226	7	312	8
125	194	200	253	9	338	10
150	224	200	283	11	368	12
200	284	200	340	14	427	15

The Table is for PN25.

** Process connection is performed through DN 15 flange*

Flanged design

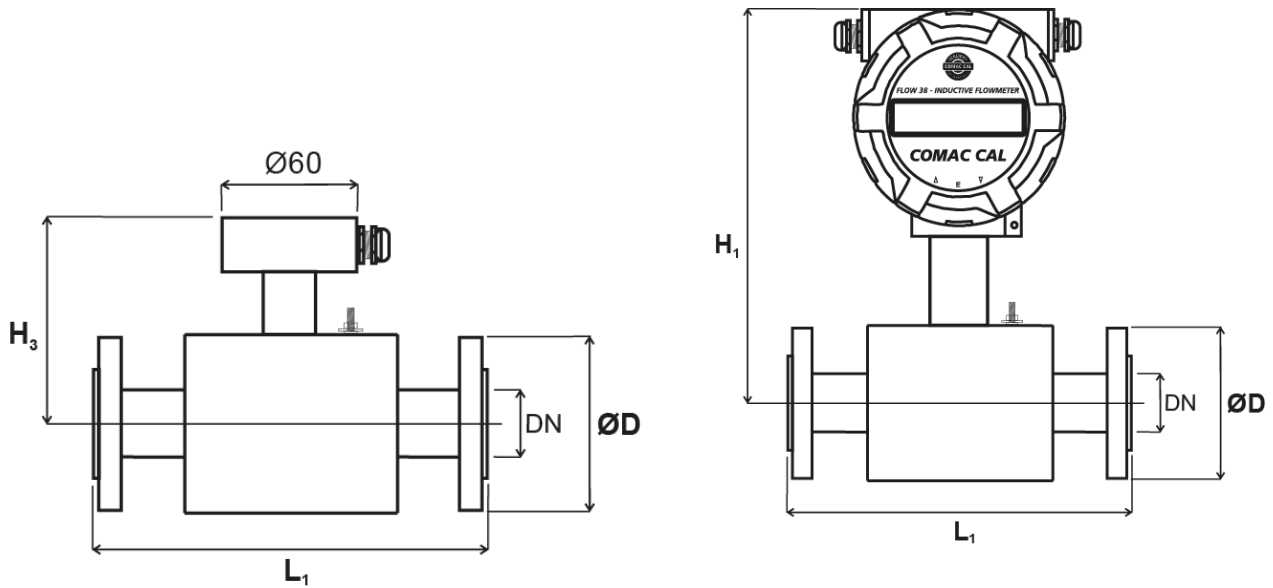

Diameter nominal [mm]	D Outside diameter of flanges	L ₁ Building length of sensor	H ₃ Building height of sensor	Weight of detached flow sensor (kg)	H ₁ Building height of comp. meter	Compact flow meter weight (kg)
10*,15	The outside diameter corresponds to the required pressure class and standards.	200	86	4	173	5
20		200	86	4	173	5
25		200	91	5	178	6
32		200	96	6	183	7
40		200	101	7	188	8
50		200	109	9	196	10
65		200	119	11	206	12
80		200	126	12	213	13
100		250	139	19	226	20
125		250	152	26	239	27
150		300	167	37	254	38
200		350	197	44	284	45
250		450	240	65	327	66
300		500	265	78	352	79
350		550	295	88	382	89
400		600	325	106	412	107
500	600	797	115	892	120	
600	600	930	125	1025	132	

The Table is up to DN 200 for PN25, DN250 and DN300 for PN16, DN350 to DN600 for PN10.

* Process connection is performed through DN 15 flange

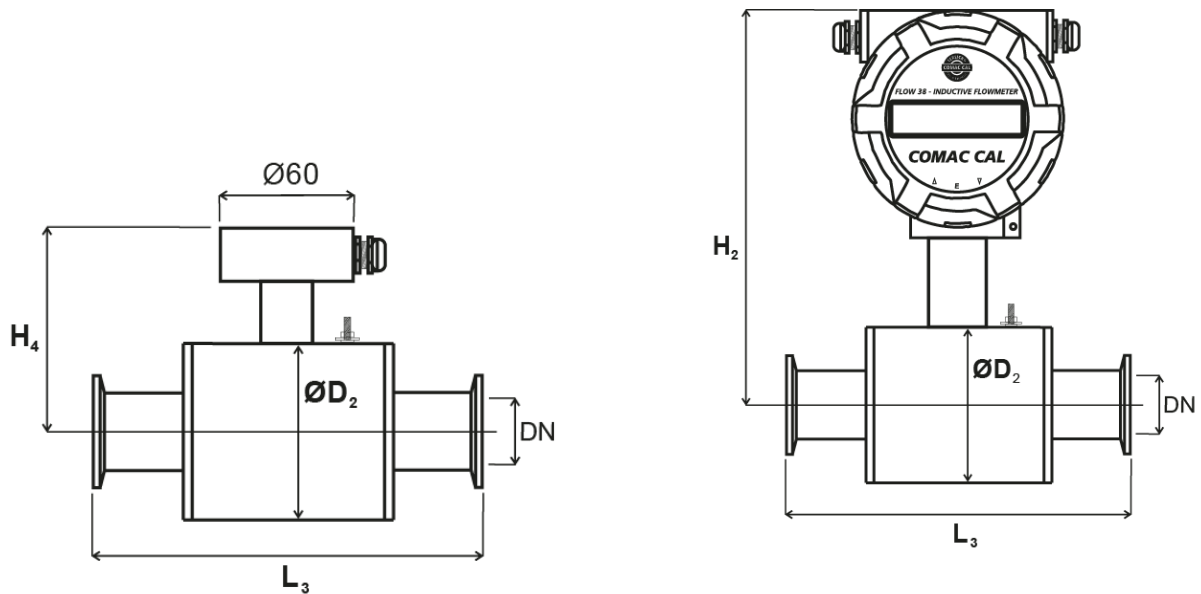

Diameter nominal [mm]	Food grade connection CLAMP/Screwed fitting	D ₂ Outside diameter of sensor	L ₃ Building length of CLAMP	L ₃ Building length of food grade screwed fitting	H ₄ Building height of sensor	Weight of detached flow sensor (kg)	H ₂ Building height of comp. meter	Compact flow meter weight (kg)
10	DN 10	70	180	173	90	4	177	5
15	DN 15	70	175	165	90	4	177	5
20	DN 20	80	175	170	95	4	182	5
25	DN 25	90	175	180	100	5	187	6
32	DN 32	100	175	192	105	5	192	6
40	DN 40	116	203	215	113	6	200	7
50	DN 50	136	211	228	123	7	210	8
65	DN 65	151	upon agreement	upon agreement	131	7	218	8
80	DN 80	177	upon agreement	upon agreement	144	8	231	9

The Table is for PN25.

Diameter nominal [mm]	DN 15...DN 20	DN 25...DN 40	DN 50	DN 65	DN 80
Outside dimension of CLAMP [mm]	34	50,5	64	91	106

Nomogram for quick proposal of the measured place

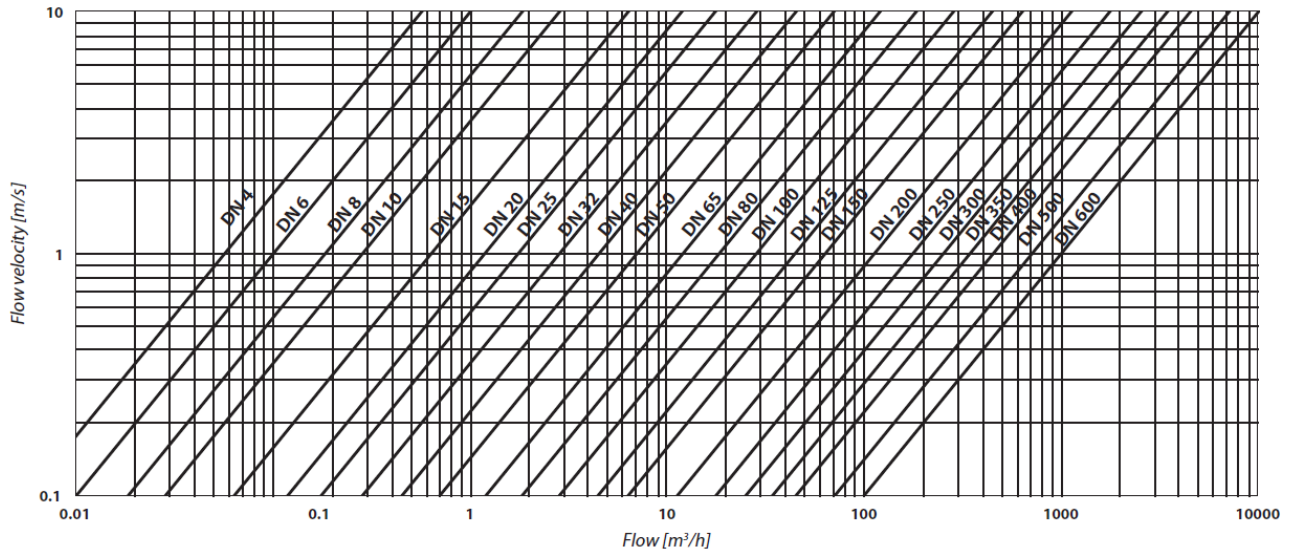

Reduction in DN pipe

If the pipe's DN is higher than that of the meter selected

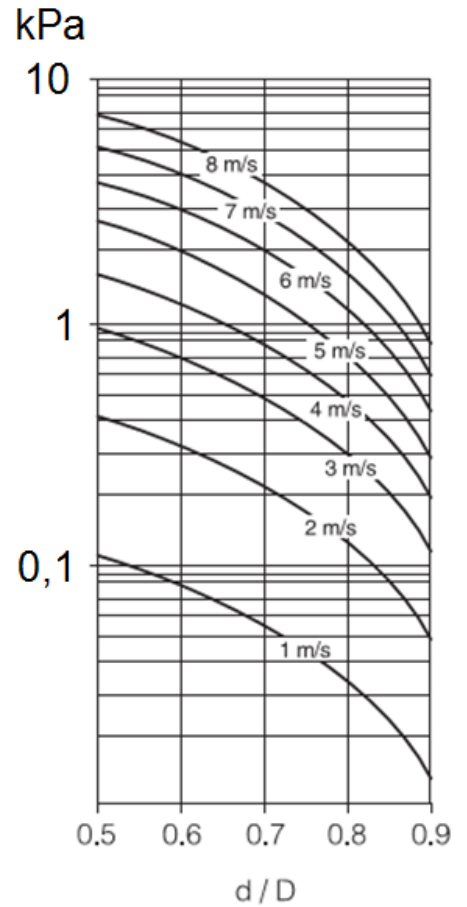
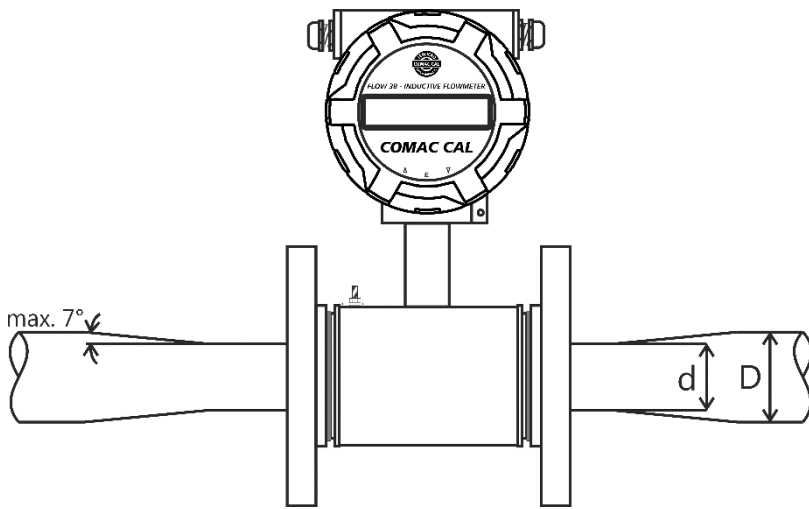

Faults and their symptoms during measurement

Unstable indications and readouts may appear due to:

- big portion of solids
- in homogeneities as a result of the state of matter
- turning point of immixture
- continuous chemical reactions in the measured fluid
- use of diaphragm pumps or plunger pumps
- poor grounding

Flow sensor cleaning

Some measured liquids contain substances and chemicals that tend to form layers inside the pipes including the measuring pipe, which may affect the measurement accuracy. In this case it is necessary to clean the flow sensor from time to time. Ceramic pipes can be cleaned mechanically with a steel brush and then the cleaning can be completed using diluted hydrochloride acid or citric acid solution. The acid removes calcareous layers or black layers of iron complex. If the contamination is greasy, it must be cleaned by caustic soda or potassium hydroxide solution. Flow sensors with teflon, plastic and rubber measuring pipe cannot be cleaned mechanically with a brush, it is only possible to clean them chemically. After cleaning, the pipe must be properly rinsed with water.

Servicing

All repairs within warranty and after warranty period are only conducted by the manufacturer, **COMAC CAL s. r.o.**

When the operations described below are carried out incompetently, the claim for warranty for errors resulting from this becomes null and void !!!

Turn off the power every time the evaluation unit is opened!!!

Returning the meter to COMAC CAL s.r.o.

The meter you have was made with the maximum precision and it has been checked many times and wet calibrated.

If the meter is used in agreement with this manual, the occurrence of faults is very rare. Should they ever occur, contact our service department. If you return the meter to the manufacturing plant, adhere to the conditions stated below:

- Clear the meter of contaminations stuck to the sensor and measuring tube (eventually to the Evaluation Unit).
- If the meter was run with poisonous, etching, combustible liquids or with fluids dangerous to water, check it and if appropriate, flush and neutralize the cavities inside the sensor.

Please attach full description of the fault. COMAC CAL s.r.o. will not be able to process your request promptly and correctly without this form.